

WE CONTROL THE FLOW

Elite provides comprehensive Valve, Automation Packages, and Instrumentation solutions for all industrial applications, ensuring optimal control of fluid flow with our expertise: "We control the flow."

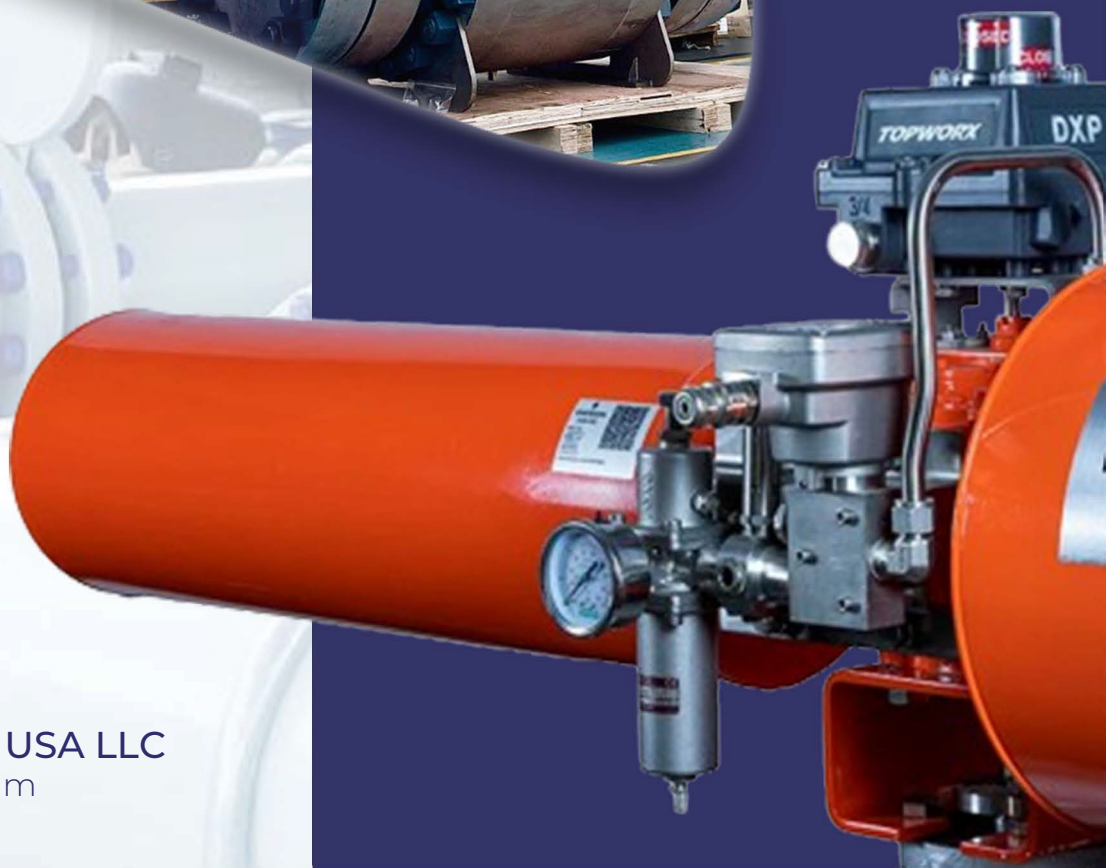

Elite Flow Control USA LLC
www.eliteflowusa.com

COMPANY PROFILE

Elite provides comprehensive Valve, Automation Packages, and Instrumentation solutions for all industrial applications, ensuring optimal control of fluid flow with our expertise: "We control the flow."

Elite Flow Control is one of the leading and renowned brand of Valves having its own independent manufacturing facilities and global existence in the United States of America, United Kingdom and China.

Our design and manufacturing range includes Ball Valves, Gate Valves, Globe Valves, Check Valves, Plug Valves, Butterfly Valves, Control Valves, Actuated Valves, and have a dedicated PTFE / PFA lining facility for PTFE / PFA Lined Valves, Pipe Spools, Pipe fittings, and associated equipment for high corrosive/chemical applications.

MISSION

ELITE FLOW CONTROL FOCUSED TO PROVIDE THE SUPERIOR QUALITY VALVES AT COMPETITIVE PRICES TO ITS CUSTOMERS AROUND THE WORLD BY UTILIZING THE COMPANY'S HUMAN RESOURCES AND ADVANCED TECHNOLOGY EQUIPMENT WITH THE STRONG COMMITMENT TO R&D, HEALTH, SAFETY, ENVIRONMENT AND COMPANY'S CORE VALUES.

VISION

TO MAKE OUR BRAND "THE FIRST CHOICE OF CUSTOMERS".

Elite Philosophy

Elite operates on philosophy to provide Immediate Response, Excellent Quality Services, Quick Delivery and Customer Satisfaction followed by our Core Values "What we commit, we deliver" based on this we are having satisfied customers in more than 25 countries and ever expanding throughout the world.

Double Acting Type - Pneumatic Actuators

High-strength Fasteners
All pressure-bearing fasteners meet the 8.8 and 12.9 grade standards to ensure product safety.

Precision Casting
The film-coated sand casting process ensures the casting quality and appearance of the product, guaranteeing the internal quality of the castings.

Dual Guideway Design
The dual guideway design with sealing teeth and wear-resistant rings provides excellent dynamic sealing performance.

Oil-free Bearings
The piston rods are designed with oil-free bearing structure, which operates smoothly. The PTFE coating of the oil-free bearings has wear-resistant, smooth and protective functions for the outer surface of the piston rod.

Toggle Nut
The open nut design allows for quick installation and eliminates looseness. The connection plate of the toggle nut meets the requirements of the S05211 standard.

ISO5211 standard
The connecting flange meets the requirements of the ISO5211 standard.

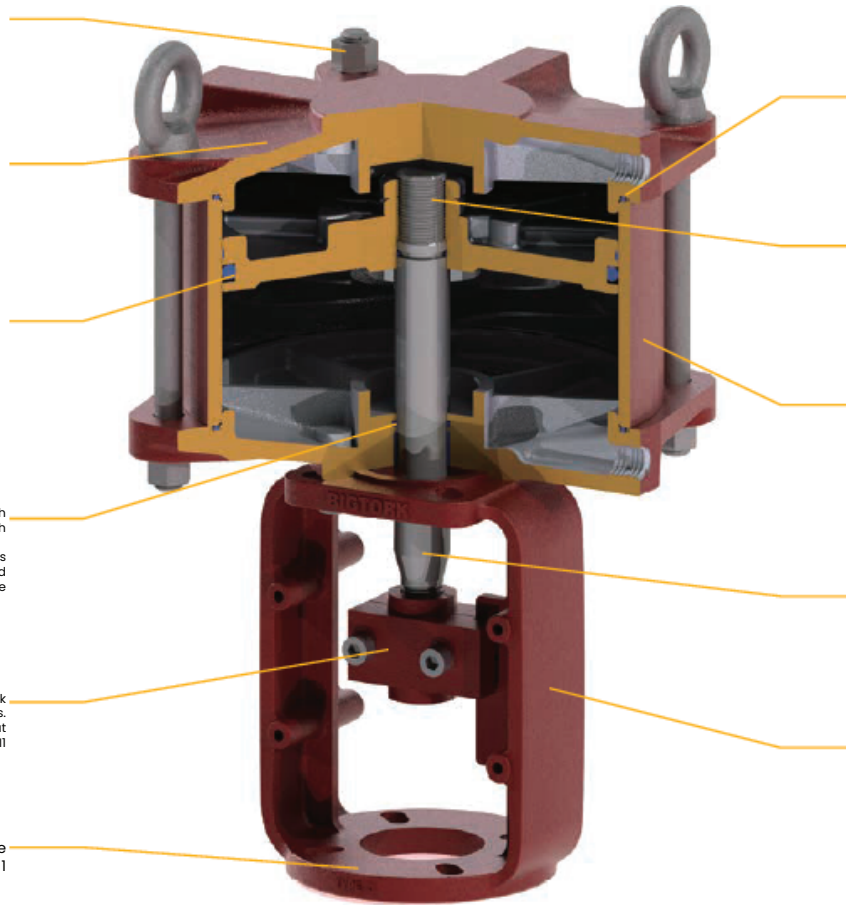

Excellent Sealing Performance
All seals use high-quality products, typically NBR under normal working conditions, and fluororubber or silicone rubber at high or low temperatures.

Reliable Connection
The piston body has its own thread, ensuring a firm and reliable connection. It is tested to switch stably for 1 million times without looseness.

Cylinder
The cylinder is made of three precision grinding processes and hard chrome plating, which is wear-resistant, corrosion-resistant and has an excellent low friction coefficient mirror-level roughness with reliable sealing.

Piston Rod
The piston rod is designed with alloy steel quenching, grinding and hard chrome plating to ensure high surface hardness while maintaining internal flexibility. It has the characteristics of wear resistance and low friction.

Special Bracket
The special bracket is convenient for installing positioners and limit switches.

Comprehensive Analytical Capacity



End Cap Stress Analysis

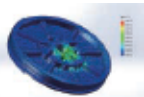

Piston Stress Analysis



Bracket Stress Analysis



Cylinder Strength Analysis



Piston rod stress analysis

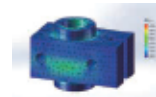

Opening and closing nut stress analysis

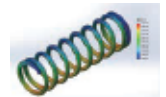

Spring Fatigue Stress Analysis

Product Features

1. Application versatility: Multiple models and sizes of actuators are available for a wide range of applications. The actuators come in different specifications of spring stiffness, travel limiters, and manual operation mechanisms, making them suitable for almost any application of control valves and switch valves.
2. Good regulation and control accuracy: The linear motion characteristic of the actuator has excellent loading pressure and stroke linearity, and high dynamic stability and frequency response characteristics.
3. High thrust bearing and pressure resistance: The overall design of the actuator meets the pressure resistance requirements under a rated air pressure of up to 1.2 MPa, which is twice that of traditional piston actuators and three times that of diaphragm actuators.
4. Self-lubricating system and guide structure: The actuator is designed with a unique self-lubricating system and guide structure, which eliminates the need for maintenance of moving parts even after years of continuous operation. The sealing ring and guide ring ensure that the cylinder piston and piston rod do not directly friction against the inner wall metal surface when subjected to lateral forces, and the annular groove is filled with lubricating grease, which can continuously lubricate the surface of the parts.
5. Long service life: The sturdy housing structure has high stability, provides corrosion protection, and prevents deformation caused by overpressure.
6. Application in low-temperature conditions: For low-temperature and ultra-low-temperature applications, the material specifications meet the requirements of low-temperature impact tests, ensuring safe operation at temperatures as low as -60 degrees Celsius.
7. Rigid connection: The opening and closing nut valve stem connection component ensures reliable motion transmission and easy installation without any connectors that can cause dead space and inaccurate valve positioning.
8. Harsh corrosive environments: The three-stage internal and external anti-corrosion coating process is used to cope with adverse weather conditions and corrosive environments.

Single-Acting with Center Manual – Pneumatic Actuators

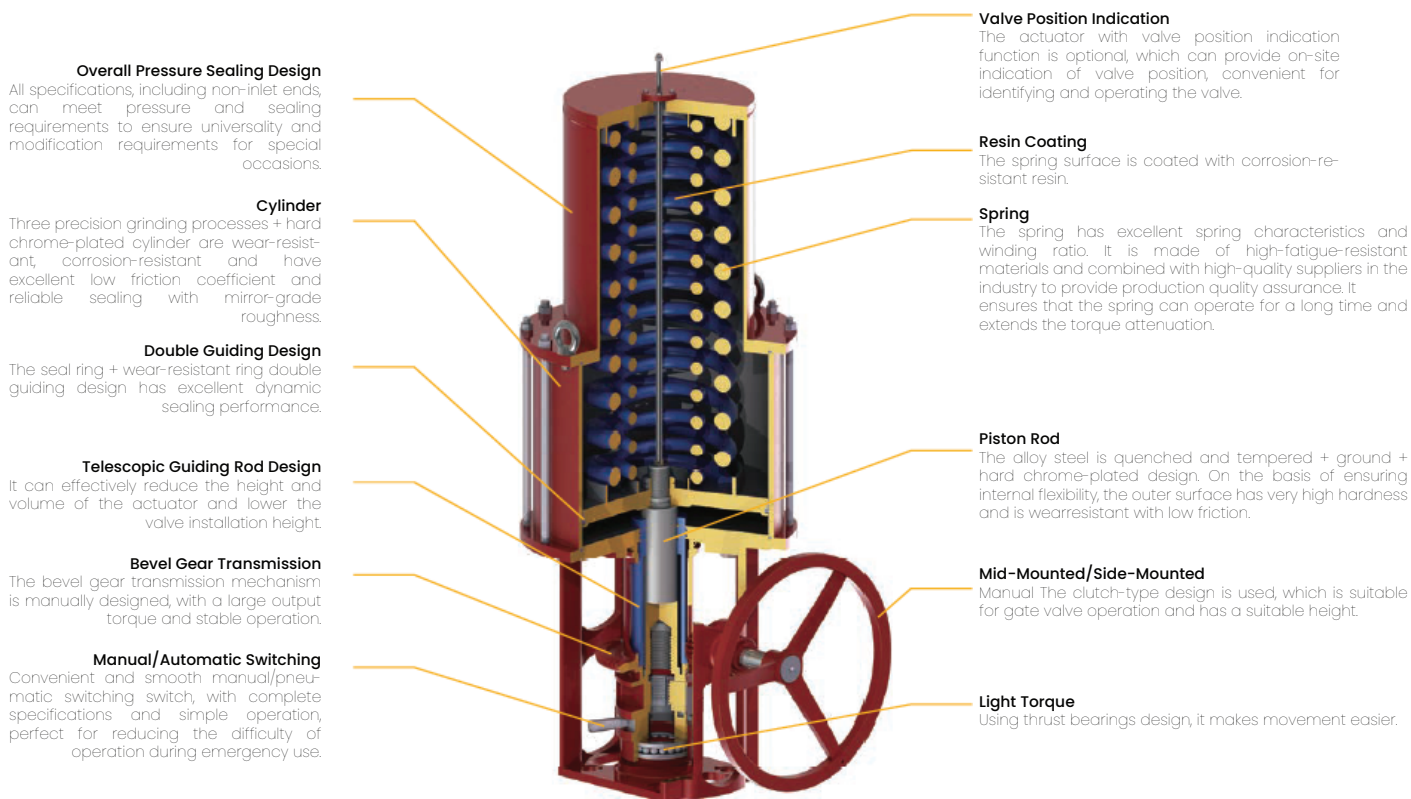

Comprehensive Analytical Capacity



Product Features

- Application versatility:** Multiple models and sizes of actuators are available for a wide range of applications. The actuators come in different specifications of spring stiffness, travel limiters, and manual operation mechanisms, making them suitable for almost any application of control valves and switch valves.
- Good regulation and control accuracy:** The linear motion characteristic of the actuator has excellent loading pressure and stroke linearity, and high dynamic stability and frequency response characteristics.
- High thrust bearing and pressure resistance:** The overall design of the actuator meets the pressure resistance requirements under a rated air pressure of up to 1.2 MPa, which is twice that of traditional piston actuators and three times that of diaphragm actuators.
- Self-lubricating system and guide structure:** The actuator is designed with a unique self-lubricating system and guide structure, which eliminates the need for maintenance of moving parts even after years of continuous operation. The sealing ring and guide ring ensure that the cylinder piston and piston rod do not directly friction against the inner wall metal surface when subjected to lateral forces, and the annular groove is filled with lubricating grease, which can continuously lubricate the surface of the parts.
- Long service life:** The sturdy housing structure has high stability, provides corrosion protection, and prevents deformation caused by overpressure.
- Application in low-temperature conditions:** For low-temperature and ultra-low-temperature applications, the material specifications meet the requirements of low-temperature impact tests, ensuring safe operation at temperatures as low as -60 degrees Celsius.
- Rigid connection:** The opening and closing nut valve stem connection component ensures reliable motion transmission and easy installation without any connectors that can cause dead space and inaccurate valve positioning.
- Harsh corrosive environments:** The three-stage internal and external anti-corrosion coating process is used to cope with adverse weather conditions and corrosive environments.

Double Acting (Double Cylinder) with Top Loading Manual Pneumatic Actuators

Manual and automatic switching
Convenient and smooth manual/pneumatic switching switch with complete documentation, simple operation, and perfect reduction of operation difficulty during emergency use.

Top-mounted side-mounted manual
Adopt a clutch-type design that is convenient to use for gate valve operation and has a suitable height.

High-strength fasteners
All pressure-bearing fasteners meet the 8.8 and 12.9 grade standards, ensuring the safety of product use.

Double-guided design
The seal ring and wear-resistant ring double-guided design has excellent dynamic sealing performance.

Oil-free bearing
The piston rod adopts an oil-free bearing structure design, which operates smoothly. The PTFE coating of the oil-free bearing has the characteristics of wear resistance, smoothness, and protection of the outer surface of the piston rod.

Open-close nut
The double-nut connection is quickly installed and eliminates looseness.



Cylinder
The three-pass precision grinding process + hard chrome plating cylinder is wear-resistant, corrosion-resistant, and has excellent low friction coefficient mirror-level roughness with reliable sealing.

Double-piston design
The output torque is twice that of ordinary cylinders. It is designed for gate valves and globe valves and can flexibly meet different valve switch torque requirements.

Piston rod
The piston rod is designed with alloy steel quenching and tempering + grinding + hard chrome plating. On the basis of ensuring internal flexibility, the outer surface has a very high hardness and has the characteristics of wear resistance and low friction.

Resin coating
The surface of the spring is coated with a corrosion-resistant resin.

Special bracket
Convenient for installing limit switches and positioners.

ISO5211 standard
The connecting flange meets the requirements of the ISO5211 standard.

Comprehensive Analytical Capacity

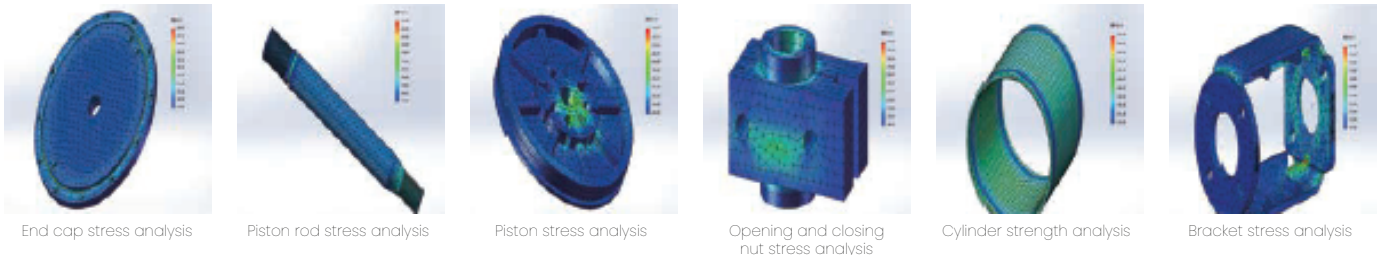

Product Features

- 1. Application versatility:** Multiple models and sizes of actuators are available for a wide range of applications. The actuators come in different specifications of spring stiffness, travel limiters, and manual operation mechanisms, making them suitable for almost any application of control valves and switch valves.
- 2. Good regulation and control accuracy:** The linear motion characteristic of the actuator has excellent loading pressure and stroke linearity, and high dynamic stability and frequency response characteristics.
- 3. High thrust bearing and pressure resistance:** The overall design of the actuator meets the pressure resistance requirements under a rated air pressure of up to 1.2 MPa, which is twice that of traditional piston actuators and three times that of diaphragm actuators.
- 4. Self-lubricating system and guide structure:** The actuator is designed with a unique self-lubricating system and guide structure, which eliminates the need for maintenance of moving parts even after years of continuous operation. The sealing ring and guide ring ensure that the cylinder piston and piston rod do not directly friction against the inner wall metal surface when subjected to lateral forces, and the annular groove is filled with lubricating grease, which can continuously lubricate the surface of the parts.
- 5. Long service life:** The sturdy housing structure has high stability, provides corrosion protection, and prevents deformation caused by overpressure.
- 6. Application in low-temperature conditions:** For low-temperature and ultra-low-temperature applications, the material specifications meet the requirements of low-temperature impact tests, ensuring safe operation at temperatures as low as -60 degrees Celsius.
- 7. Rigid connection:** The opening and closing nut valve stem connection component ensures reliable motion transmission and easy installation without any connectors that can cause dead space and inaccurate valve positioning.
- 8. Harsh corrosive environments:** The three-stage internal and external anti-corrosion coating process is used to cope with adverse weather conditions and corrosive environments.

Integral pressure sealing design
All specifications, including non-intake ends, can meet the pressure and sealing requirements, ensuring versatility and retrofitting requirements for special occasions.

Resin coating
The surface of the spring is coated with corrosion-resistant resin.

Cylinder
The cylinder is processed through three precise grinding processes and hard chrome plating, making it wear-resistant, corrosion-resistant, and with excellent low friction coefficient, mirror-grade roughness and reliable sealing.

Bidirectional design
The dynamic sealing performance of the seal ring and wear-resistant ring bidirectional design is excellent.

Air supply interface
Multiple air supply interface sizes are available.

Piston rod
The piston rod is designed with alloy steel quenching and tempering, grinding and hard chrome plating. On the basis of ensuring internal flexibility, the surface has high hardness, wear resistance, and low friction coefficient.

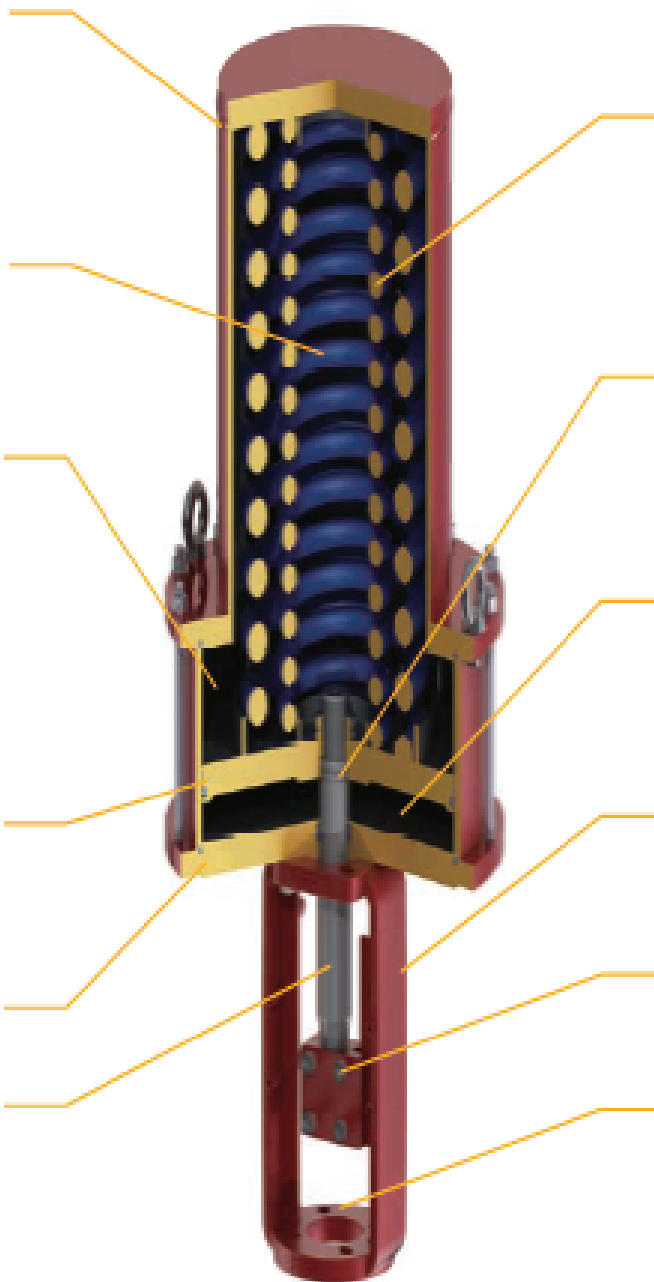

Spring
The spring has excellent spring characteristics and winding ratio, and is made of high fatigueresistant materials, combined with industry-leading suppliers to provide production quality assurance. Ensure that the spring can operate for a long time and extend torque attenuation.

Excellent sealing performance
All sealing components are made of high-quality products. Nitrile rubber is generally used under normal working conditions, and fluorine rubber or silicone rubber is used at high or low temperatures.

Adjustable stroke option
For special requirements, the adjustable stroke structure can be selected for bidirectional position adjustment of full open and full close.

Dedicated bracket
Convenient for installing limit switches and positioners.

Open-close nut
The opening-closing nut is connected and installed quickly, and loosening is avoided.

ISO5211 standard
The connection flange meets the requirements of the ISO5211 standard.

Comprehensive Analytical Capacity

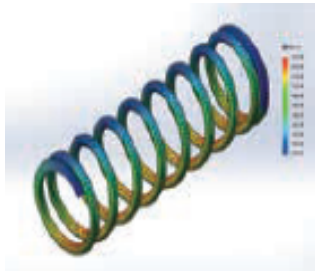

Spring fatigue stress analysis

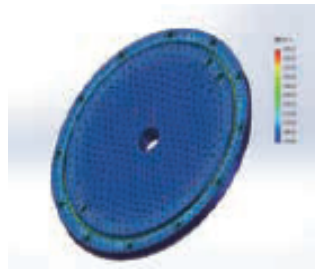

End cap stress analysis

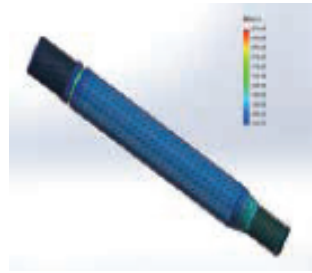

Piston rod stress analysis

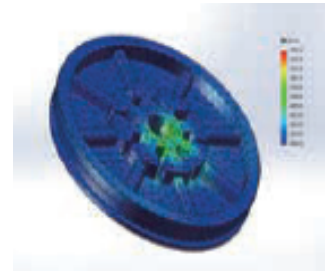

Piston stress analysis

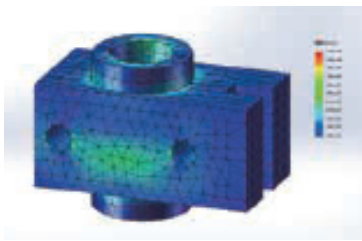

Opening and closing nut stress analysis

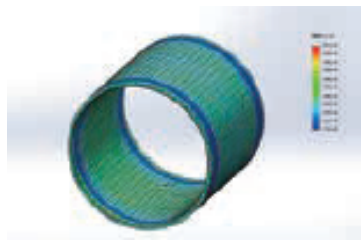

Cylinder strength analysis



Bracket stress analysis

1. Application versatility: Multiple models and sizes of actuators are available for a wide range of applications. The actuators come in different specifications of spring stiffness, travel limiters, and manual operation mechanisms, making them suitable for almost any application of control valves and switch valves.
2. Good regulation and control accuracy: The linear motion characteristic of the actuator has excellent loading pressure and stroke linearity, and high dynamic stability and frequency response characteristics.
3. High thrust bearing and pressure resistance: The overall design of the actuator meets the pressure resistance requirements under a rated air pressure of up to 1.2 MPa, which is twice that of traditional piston actuators and three times that of diaphragm actuators.
4. Self-lubricating system and guide structure: The actuator is designed with a unique self-lubricating system and guide structure, which eliminates the need for maintenance of moving parts even after years of continuous operation. The sealing ring and guide ring ensure that the cylinder piston and piston rod do not directly friction against the inner wall metal surface when subjected to lateral forces, and the annular groove is filled with lubricating grease, which can continuously lubricate the surface of the parts.
5. Long service life: The sturdy housing structure has high stability, provides corrosion protection, and prevents deformation caused by overpressure.
6. Application in low-temperature conditions: For low-temperature and ultra-low-temperature applications, the material specifications meet the requirements of low-temperature impact tests, ensuring safe operation at temperatures as low as -60 degrees Celsius.
7. Rigid connection: The opening and closing nut valve stem connection component ensures reliable motion transmission and easy installation without any connectors that can cause dead space and inaccurate valve positioning.
8. Harsh corrosive environments: The three-stage internal and external anti-corrosion coating process is used to cope with adverse weather conditions and corrosive environments.

Available Configuration

Direct Action

All FO-type actuators are direct action. Applying gas source pressure to the upper gas chamber piston can cause the actuator stem to move downward. When the pressure drops, the opposing spring force moves the actuator stem upward. If the loaded pressure fails, the spring forces the stem to move up to the top position.

This provides a fail-open mode for valves that close when pushed down, and a fail-close mode for valves that open when pushed down.

Instruments

Handwheel

In emergency situations, they can also serve as on-site means of operating opening and closing valve. Handwheels are divided into top-mounted manual, top-mounted side-mounted manual, center-mounted side-mounted manual, and hydraulic manual according to size specifications.

Top-mounted manual

The handwheel is mounted on the top cover of the cylinder and is generally suitable for smaller size actuators. A typical structural diagram is shown in xxxx.

Top-mounted side-mounted manual

The handwheel is mounted on the top cover of the cylinder and is designed with a gear transmission mechanism. It can output a larger torque. A typical structural diagram is shown in xxxx.

Center-mounted side-mounted manual

The handwheel is mounted in the middle of the cylinder and valve bracket and is designed with a gear transmission mechanism. It can output a larger torque. A typical structural diagram is shown in xxxx.

Hydraulic manual

Driven by a hydraulic manual pump, it is suitable for manual operation of larger size actuators.

Reverse Action

All FC-type actuators are reverse action. Applying gas source pressure to the lower gas chamber piston can overcome the opposing spring force and push the actuator stem upward. When this loaded pressure decreases, the spring pushes the actuator stem downward. If the loaded pressure fails, the spring forces the stem to move down to the bottom position. These actuators provide a fail-close mode for valves that are pushed down to close and a fail-open mode for valves that are pushed down to open.

Adjustable stroke limiter

All actuators can be equipped with adjustable stroke limiters to limit stroke in the up, down, or up-down directions.

Air storage tank

For valves that require safe operation in case of air source failure, we can provide air storage tanks.

Other accessories

Other accessories such as converters, valve positioners, valve position transmitters, gas pneumatic amplifiers, switching valves, locking valves, limit switches, and solenoid valves can be installed in conjunction with actuators. They are described in separate product brochures. For details, please contact the sales department of our company.

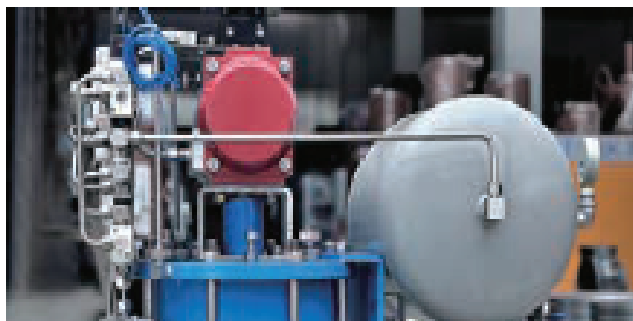

Working Principles

Double-acting double cylinders

As shown in the figure, when compressed air enters the cylinder from the lower intake port and acts on the upper and lower pistons, the piston moves in the direction indicated by the arrow, driving the piston rod upwards and causing the valve plate to move in the open direction.

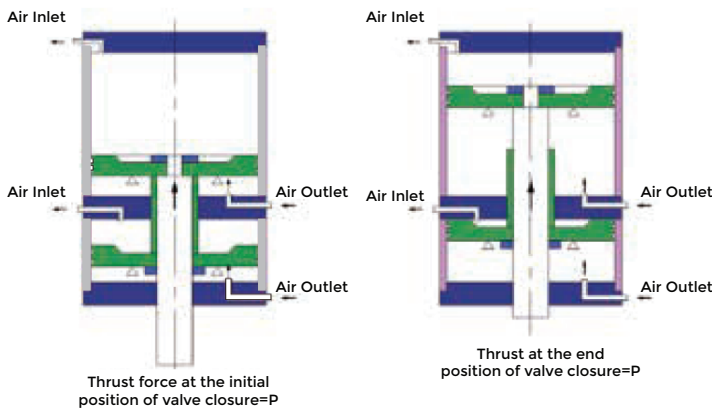
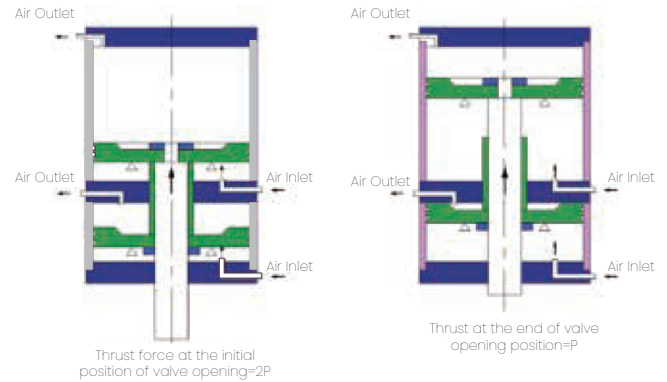

At this time, the excess air generated by the change in chamber volume is discharged from the exhaust port. When compressed air enters the cylinder from the upper intake port, the opposite occurs, causing the valve plate to move in the closed direction and the excess air to be discharged from the exhaust port.

Double-acting single cylinder

As shown in the figure, when compressed air enters the cylinder from the upper intake port, the air pressure acts on the piston, causing the piston to move in the direction indicated by the arrow, driving the piston rod downwards and causing the valve plate to move in the closed direction. Conversely, when compressed air enters the cylinder from the lower intake port, the piston moves in the opposite direction and the valve plate moves in the open direction.

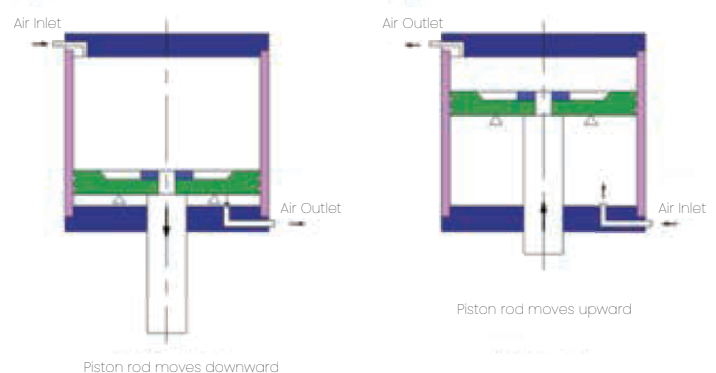

Working Principles

Single-Acting Air Open

As shown in the figure, when compressed air enters the cylinder from the lower intake port, the air pressure acts on the piston, compressing the spring and causing the piston to move in the direction indicated by the arrow. At this time, the excess air generated by the change in chamber volume is discharged from the exhaust port. Conversely, when the lower intake port exhausts, the spring overcomes the pressure in the cylinder and moves downwards.

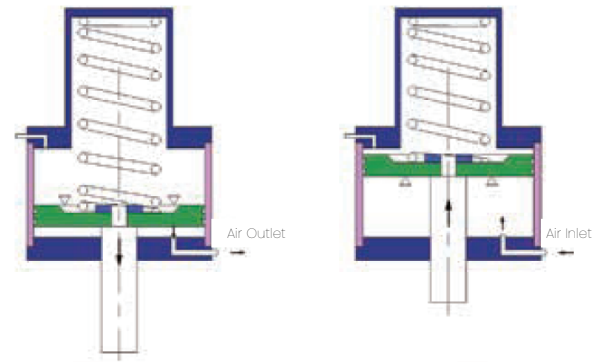

Single-acting air close

As shown in the figure, when compressed air enters the cylinder from the upper intake port, the air pressure acts on the piston, compressing the spring and causing the piston to move in the direction indicated by the arrow. At this time, the excess air generated by the change in chamber volume is discharged from the exhaust port. Conversely, when the upper intake port exhausts, the spring overcomes the pressure in the cylinder and moves upwards.



Output Torque of Actuator Double Acting – Single Cylinder

Actuator specifications	Number of pistons	Output torque with different air sources (kN)				
		0.3	0.4	0.5	0.6	0.7
ZS125	1	3.4	4.5	5.6	6.8	7.9
ZS160	1	5.5	7.4	9.2	11.1	12.9
ZS200	1	8.9	11.8	14.8	17.7	20.7
ZS250	1	13.8	18.5	23.1	27.7	32.3
ZS300	1	20.4	27.1	33.9	40.7	47.5
ZS350	1	27.7	36.9	46.2	55.4	64.7
ZS400	1	36.2	48.3	60.3	72.4	84.4
ZS450	1	45.8	61.1	76.3	91.6	106.9
ZS500	1	57.7	77.0	96.2	115.5	134.7
ZS550	1	69.8	93.1	116.4	139.7	163.0
ZS600	1	83.1	110.8	138.5	166.2	194.0
ZS700	1	114.3	152.4	190.5	228.6	266.7
ZS800	1	149.3	199.0	248.8	298.6	348.3
ZS900	1	188.9	251.9	314.9	377.9	440.9
ZS1000	1	233.3	311.0	388.8	466.5	544.3
ZS1100	1	282.2	376.3	470.4	564.5	658.6

- Note: 1. BTO/RTO/ETO and BTC/RTC/ETC have the same output torque.
 2. The output torque in the table does not consider the influence of the piston rod.
 3. The piston rod's cross-sectional area has a certain effect on the effective area of the cylinder, which may slightly reduce the theoretical output torque, but the impact is minimal and can be neglected.

Double Acting-Single Cylinder Output Torque Chart

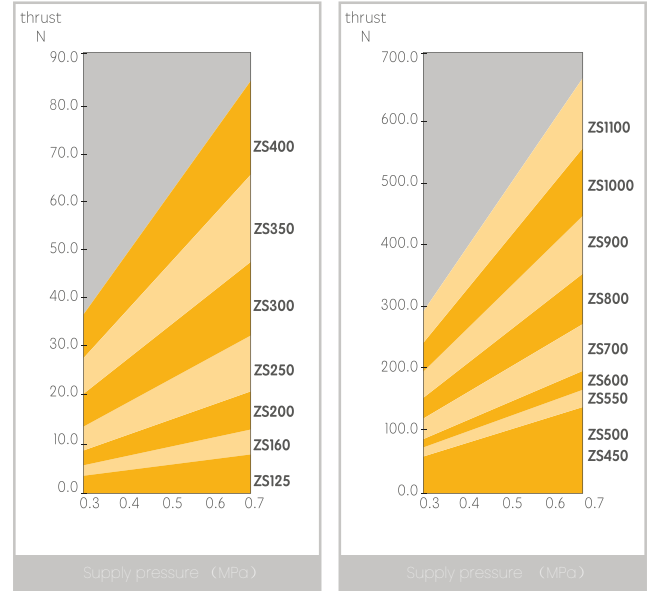

Double Acting – Double Cylinder (Series)

Actuator specifications	Number of pistons	Output torque with different air sources (kN)				
		0.3	0.4	0.5	0.6	0.7
ZS125/2C	2	6.8	9.0	11.3	13.5	15.8
ZS160/2C	2	11.1	14.8	18.5	22.2	25.9
ZS200/2C	2	17.7	23.6	29.5	35.4	41.3
ZS250/2C	2	27.7	36.9	46.1	55.4	64.6
ZS300/2C	2	40.7	54.3	67.9	81.4	95.0
ZS350/2C	2	55.4	73.9	92.4	110.8	129.3
ZS400/2C	2	72.4	96.5	120.6	144.8	168.9
ZS450/2C	2	91.6	122.1	152.7	183.2	213.7
ZS500/2C	2	115.5	153.9	192.4	230.9	269.4
ZS550/2C	2	139.7	186.3	232.8	279.4	326.0
ZS600/2C	2	166.2	221.7	277.1	332.5	387.9
ZS700/2C	2	228.6	304.8	381.0	457.2	533.4
ZS800/2C	2	298.6	398.1	497.6	597.1	696.7
ZS900/2C	2	377.9	503.8	629.8	755.8	881.7
ZS1000/2C	2	466.5	622.0	777.5	933.0	1088.5
ZS1100/2C	2	564.5	752.6	940.8	1129.0	1317.1

- Note: 1. BTO/RTO/ETO have the same torque, and BTC/RTC/ETC have the same torque.
 2. The output torque in the table does not consider the influence of the piston rod.
 3. The piston rod's cross-sectional area has a certain effect on the effective area of the cylinder, which may slightly reduce the theoretical output torque, but the impact is minimal and can be neglected.
 4. Adopting a series-connected dual-cylinder design, the opening and closing output torques are both the torque of the two cylinders.

Double Acting – Double Cylinder (Tandem) Output Torque Charts

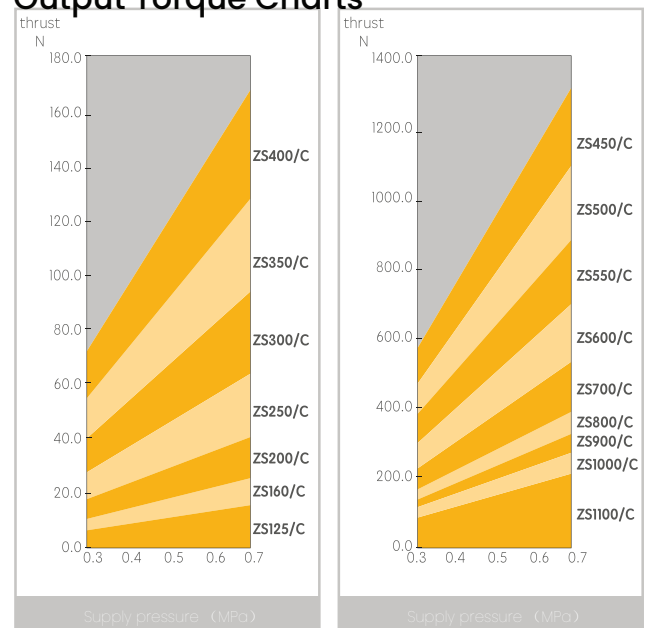

Double Acting - Double Cylinder (Auxiliary Cylinder)

Actuator specifications	Number of pistons	Output torque with different air sources (kN)									
		0.3		0.4		0.5		0.6		0.7	
		开方向	关方向	开方向	关方向	开方向	关方向	开方向	关方向	开方向	关方向
ZS125/2	2	6.8	3.4	9.0	4.5	11.3	5.6	13.5	6.8	15.8	7.9
ZS160/2	2	11.1	5.5	14.8	7.4	18.5	9.2	22.2	11.1	25.9	12.9
ZS200/2	2	17.7	8.9	23.6	11.8	29.5	14.8	35.4	17.7	41.3	20.7
ZS250/2	2	27.7	13.8	36.9	18.5	46.1	23.1	55.4	27.7	64.6	32.3
ZS300/2	2	40.7	20.4	54.3	27.1	67.9	33.9	81.4	40.7	95.0	47.5
ZS350/2	2	55.4	27.7	73.9	36.9	92.4	46.2	110.8	55.4	129.3	64.7
ZS400/2	2	72.4	36.2	96.5	48.3	120.6	60.3	144.8	72.4	168.9	84.4
ZS450/2	2	91.6	45.8	122.1	61.1	152.7	76.3	183.2	91.6	213.7	106.9
ZS500/2	2	115.5	57.7	153.9	77.0	192.4	96.2	230.9	115.5	269.4	134.7
ZS550/2	2	139.7	69.8	186.3	93.1	232.8	116.4	279.4	139.7	326.0	163.0
ZS600/2	2	166.2	83.1	221.7	110.8	277.1	138.5	332.5	166.2	387.9	194.0
ZS700/2	2	228.6	114.3	304.8	152.4	381.0	190.5	457.2	228.6	533.4	266.7
ZS800/2	2	298.6	149.3	398.1	199.0	497.6	248.8	597.1	298.6	696.7	348.3
ZS900/2	2	377.9	188.9	503.8	251.9	629.8	314.9	755.8	377.9	881.7	440.9
ZS1000/2	2	466.5	233.3	622.0	311.0	777.5	388.8	933.0	466.5	1088.5	544.3
ZS1100/2	2	564.5	282.2	752.6	376.3	940.8	470.4	1129.0	564.5	1317.1	658.6

- Note: 1. BTO is the opening force, and ETC is the closing force (for valves where the majority of piston rods extend in the closing direction).
 2. The output torque in the table does not consider the influence of the piston rod.
 3. The piston rod's cross-sectional area has a certain effect on the effective area of the cylinder, which may slightly reduce the theoretical output torque, but the impact is minimal and can be neglected.
 4. This table is suitable for top-discharge valves with a normally open type. For other valves with similar switch directions opposite to the conventional ones, attention should be paid to the selection of air-open and air-close.

Double Acting Actuator Torque Curve Graph

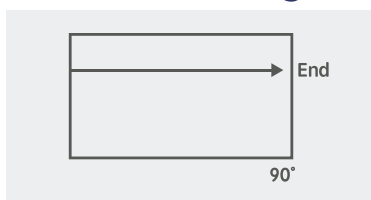

Single Acting Actuator Torque Curve Graph

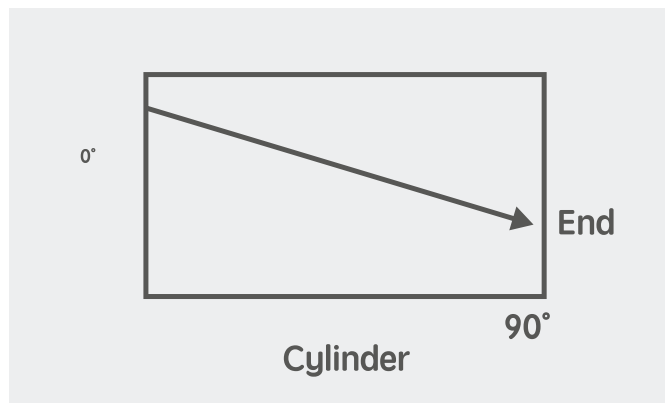

Single-Acting Air-Open - Single-Cylinder

When the air supply is lost, the piston rod extends.

Actuator specifications	Number of pistons	Spring reset torque kN	Output torque under different air sources (kN)				Actuator specifications	Number of pistons	Spring reset torque kN	Output torque under different air sources (kN)			
			0.4	0.5	0.6	0.4				0.5	0.6		
			ETC	BTO	BTO	BTO				ETC	BTO	BTO	BTO
ZSS160 SR4	1	3.0	4.4	6.3	8.1	ZSS500 SR6	1	48.1	28.9	48.1	67.3		
ZSS160 SR5	1	3.7	3.7	5.5	7.4	ZSS550 SR4	1	37.3	55.9	79.2	102.4		
ZSS160 SR6	1	4.6	2.8	4.6	6.5	ZSS550 SR5	1	46.6	46.6	69.8	93.1		
ZSS200 SR4	1	4.7	7.1	10.0	13.0	ZSS550 SR6	1	58.2	34.9	58.2	81.5		
ZSS200 SR5	1	5.9	5.9	8.9	11.8	ZSS600 SR4	1	44.3	66.5	94.2	121.9		
ZSS200 SR6	1	7.4	4.4	7.4	10.3	ZSS600 SR5	1	55.4	55.4	83.1	110.8		
ZSS250 SR4	1	7.4	11.1	15.7	20.3	ZSS600 SR6	1	69.3	41.6	69.3	97.0		
ZSS250 SR5	1	9.2	9.2	13.8	18.5	ZSS700 SR4	1	61.0	91.4	129.5	167.6		
ZSS250 SR6	1	11.5	6.9	11.5	16.1	ZSS700 SR5	1	76.2	76.2	114.3	152.4		
ZSS300 SR4	1	10.9	16.3	23.1	29.9	ZSS700 SR6	1	95.2	57.1	95.2	133.3		
ZSS300 SR5	1	13.6	13.6	20.4	27.1	ZSS800 SR4	1	79.6	119.4	169.2	218.9		
ZSS300 SR6	1	17.0	10.2	17.0	23.7	ZSS800 SR5	1	99.5	99.5	149.3	199.0		
ZSS350 SR4	1	14.8	22.2	31.4	40.6	ZSS800 SR6	1	124.4	74.6	124.4	174.2		
ZSS350 SR5	1	18.5	18.5	27.7	36.9	ZSS900 SR4	1	100.8	151.2	214.1	277.1		
ZSS350 SR6	1	23.1	13.9	23.1	32.3	ZSS900 SR5	1	126.0	126.0	188.9	251.9		
ZSS400 SR4	1	19.3	29.0	41.0	53.1	ZSS900 SR6	1	157.4	94.5	157.4	220.4		
ZSS400 SR5	1	24.1	24.1	36.2	48.3	ZSS1000 SR4	1	124.4	186.6	264.4	342.1		
ZSS400 SR6	1	30.2	18.1	30.2	42.2	ZSS1000 SR5	1	155.5	155.5	233.3	311.0		
ZSS450 SR4	1	24.4	36.6	51.9	67.2	ZSS1000 SR6	1	194.4	116.6	194.4	272.1		
ZSS450 SR5	1	30.5	30.5	45.8	61.1	ZSS1100 SR4	1	150.5	225.8	319.9	414.0		
ZSS450 SR6	1	38.2	22.9	38.2	53.4	ZSS1100 SR5	1	188.2	188.2	282.2	376.3		
ZSS500 SR4	1	30.8	46.2	65.4	84.7	ZSS1100 SR6	1	235.2	141.1	235.2	329.3		
ZSS500 SR5	1	38.5	38.5	57.7	77.0								

Note: 1. BTO is the opening force, and ETC is the closing force (for valves where the majority of piston rods extend in the closing direction).

2. The output torque in the table does not consider the influence of the piston rod.

3. The piston rod's cross-sectional area has a certain effect on the effective area of the cylinder, which may slightly reduce the theoretical output torque, but the impact is minimal and can be neglected.

4. This table is suitable for top-discharge valves with a normally open type. For other valves with similar switch directions opposite to the conventional ones, attention should be paid to the selection of air-open and air-close.

5. For some special strokes, the above data may vary. Please refer to the actual inquiry torque.

Single Acting - Air-Close Single-Cylinder

When the air supply is lost, the piston rod retracts.

Actuator specifications	Number of pistons	Spring reset torque kN	Output torque under different air sources (kN)		
			0.4	0.5	0.6
			BTO	ETC	ETC
ZSS160 SR4	1	4.4	3.0	4.8	6.7
ZSS160 SR5	1	5.5	1.8	3.7	5.5
ZSS160 SR6	1	6.5	0.9	2.8	4.6
ZSS200 SR4	1	7.1	4.7	7.7	10.6
ZSS200 SR5	1	8.9	3.0	5.9	8.9
ZSS200 SR6	1	10.3	1.5	4.4	7.4
ZSS250 SR4	1	11.1	7.4	12.0	16.6
ZSS250 SR5	1	13.8	4.6	9.2	13.8
ZSS250 SR6	1	16.1	2.3	6.9	11.5
ZSS300 SR4	1	16.3	10.9	17.6	24.4
ZSS300 SR5	1	20.4	6.8	13.6	20.4
ZSS300 SR6	1	23.7	3.4	10.2	17.0
ZSS350 SR4	1	22.2	14.8	24.0	33.2
ZSS350 SR5	1	27.7	9.2	18.5	27.7
ZSS350 SR6	1	32.3	4.6	13.9	23.1
ZSS400 SR4	1	29.0	19.3	31.4	43.4
ZSS400 SR5	1	36.2	12.1	24.1	36.2
ZSS400 SR6	1	42.2	6.0	18.1	30.2
ZSS450 SR4	1	36.6	24.4	39.7	55.0
ZSS450 SR5	1	45.8	15.3	30.5	45.8
ZSS450 SR6	1	53.4	7.6	22.9	38.2
ZSS500 SR4	1	46.2	30.8	50.0	69.3
ZSS500 SR5	1	57.7	19.2	38.5	57.7

Actuator specifications	Number of pistons	Spring reset torque kN	Output torque under different air sources (kN)		
			0.4	0.5	0.6
			BTO	ETC	ETC
ZSS500 SR6	1	67.3	9.6	28.9	48.1
ZSS550 SR4	1	55.9	37.3	60.5	83.8
ZSS550 SR5	1	69.8	23.3	46.6	69.8
ZSS550 SR6	1	81.5	11.6	34.9	58.2
ZSS600 SR4	1	66.5	44.3	72.0	99.7
ZSS600 SR5	1	83.1	27.7	55.4	83.1
ZSS600 SR6	1	97.0	13.9	41.6	69.3
ZSS700 SR4	1	91.4	61.0	99.1	137.2
ZSS700 SR5	1	114.3	38.1	76.2	114.3
ZSS700 SR6	1	133.3	19.0	57.1	95.2
ZSS800 SR4	1	119.4	79.6	129.4	179.1
ZSS800 SR5	1	149.3	49.8	99.5	149.3
ZSS800 SR6	1	174.2	24.9	74.6	124.4
ZSS900 SR4	1	151.2	100.8	163.7	226.7
ZSS900 SR5	1	188.9	63.0	126.0	188.9
ZSS900 SR6	1	220.4	31.5	94.5	157.4
ZSS1000 SR4	1	186.6	124.4	202.2	279.9
ZSS1000 SR5	1	233.3	77.8	155.5	233.3
ZSS1000 SR6	1	272.1	38.9	116.6	194.4
ZSS1100 SR4	1	225.8	150.5	244.6	338.7
ZSS1100 SR5	1	282.2	94.1	188.2	282.2
ZSS1100 SR6	1	329.3	47.0	141.1	235.2

- Note: 1. BTO is the opening force, and ETC is the closing force (for valves where the majority of piston rods extend in the closing direction).
2. The output torque in the table does not consider the influence of the piston rod.
3. The piston rod's cross-sectional area has a certain effect on the effective area of the cylinder, which may slightly reduce the theoretical output torque, but the impact is minimal and can be neglected.
4. This table is suitable for top-discharge valves with a normally closed type. For other valves with similar switch directions opposite to the conventional ones, attention should be paid to the selection of air-open and air-close.
5. For some special strokes, the above data may vary. Please refer to the actual inquiry torque.

Air Consumption of Actuator

Double-acting - Single Cylinder

Model	Stroke	Air consumption(L)	
		Opening	Closing
ZS125	40	0.6	0.7
	60	0.9	1
ZS160	40	1.1	1.2
	75	1.9	2
	110	2.7	2.8
ZS200	40	2.1	2.2
	75	3.0	3.1
	110	4.3	4.4
	130	4.9	5
	155	5.8	6
ZS250	40	3.4	3.5
	110	6.8	7
	130	7.9	8
	155	8.9	9.1
	180	10.0	10.3
	230	12.6	12.8
ZS300	75	6.3	6.4
	180	14.6	14.8
	230	18.3	18.4
	280	21.8	21.9
ZS350	75	8.6	8.7
	230	24.7	25
	280	29.8	30
	330	34.8	35
ZS400	100	16.1	16.3
	280	38.9	39
	330	45.0	45.1
	380	51.2	51.5
	430	55.8	57.8
ZS450	100	20.6	20.7
	330	57.4	57.52
	380	65.0	65.2
	430	72.5	73.1
	480	64.8	65.2

Model	Stroke	Air consumption(L)	
		Opening	Closing
ZS500	150	35.2	35.3
	380	80.1	80.5
	430	89.8	90.3
	480	99.8	100
	530	109.4	109.9
ZS550	150	42.6	42.7
	430	108.8	109.2
	480	120.6	121.1
	530	132.4	133
	630	156.1	156.7
ZS600	200	64.8	65
	480	143.6	144.1
	530	157.6	158.3
	630	185.0	186.5
	730	214.0	214.8
ZS700	200	88.0	88.5
	630	253.0	253.9
	730	292.0	293
	850	337.0	339
ZS800	200	115.0	115.6
	730	381.0	382
	850	441.0	442
	950	491.0	492.5
ZS900	250	177.0	178
	850	558.0	559.5
	950	622.0	623
	1050	685.0	687
ZS1000	300	258.0	259
	950	768.0	769
	1050	847.0	849
	1150	925.0	927
ZS1100	300	313.0	314
	1050	1024.0	1025
	1150	1119.0	1120
	1300	1263	1265



Double Acting - Double Cylinder (Auxiliary Cylinder)

Actuator specifications	Number of pistons	Spring reset torque kN	Output torque under different air sources (kN)			Actuator specifications	Number of pistons	Spring reset torque kN	Output torque under different air sources (kN)		
			0.4	0.5	0.6				0.4	0.5	0.6
			BTO	ETC	ETC				ETC	BTO	ETC
ZSS160 SR4	1	4.4	3.0	4.8	6.7	ZSS500 SR6	1	67.3	9.6	28.9	48.1
ZSS160 SR5	1	5.5	1.8	3.7	5.5	ZSS550 SR4	1	55.9	37.3	60.5	83.8
ZSS160 SR6	1	6.5	0.9	2.8	4.6	ZSS550 SR5	1	69.8	23.3	46.6	69.8
ZSS200 SR4	1	7.1	4.7	7.7	10.6	ZSS550 SR6	1	81.5	11.6	34.9	58.2
ZSS200 SR5	1	8.9	3.0	5.9	8.9	ZSS600 SR4	1	66.5	44.3	72.0	99.7
ZSS200 SR6	1	10.3	1.5	4.4	7.4	ZSS600 SR5	1	83.1	27.7	55.4	83.1
ZSS250 SR4	1	11.1	7.4	12.0	16.6	ZSS600 SR6	1	97.0	13.9	41.6	69.3
ZSS250 SR5	1	13.8	4.6	9.2	13.8	ZSS700 SR4	1	91.4	61.0	99.1	137.2
ZSS250 SR6	1	16.1	2.3	6.9	11.5	ZSS700 SR5	1	114.3	38.1	76.2	114.3
ZSS300 SR4	1	16.3	10.9	17.6	24.4	ZSS700 SR6	1	133.3	19.0	57.1	95.2
ZSS300 SR5	1	20.4	6.8	13.6	20.4	ZSS800 SR4	1	119.4	79.6	129.4	179.1
ZSS300 SR6	1	23.7	3.4	10.2	17.0	ZSS800 SR5	1	149.3	49.8	99.5	149.3
ZSS350 SR4	1	22.2	14.8	24.0	33.2	ZSS800 SR6	1	174.2	24.9	74.6	124.4
ZSS350 SR5	1	27.7	9.2	18.5	27.7	ZSS900 SR4	1	151.2	100.8	163.7	226.7
ZSS350 SR6	1	32.3	4.6	13.9	23.1	ZSS900 SR5	1	188.9	63.0	126.0	188.9
ZSS400 SR4	1	29.0	19.3	31.4	43.4	ZSS900 SR6	1	220.4	31.5	94.5	157.4
ZSS400 SR5	1	36.2	12.1	24.1	36.2	ZSS1000 SR4	1	186.6	124.4	202.2	279.9
ZSS400 SR6	1	42.2	6.0	18.1	30.2	ZSS1000 SR5	1	233.3	77.8	155.5	233.3
ZSS450 SR4	1	36.6	24.4	39.7	55.0	ZSS1000 SR6	1	272.1	38.9	116.6	194.4
ZSS450 SR5	1	45.8	15.3	30.5	45.8	ZSS1100 SR4	1	225.8	150.5	244.6	338.7
ZSS450 SR6	1	53.4	7.6	22.9	38.2	ZSS1100 SR5	1	282.2	94.1	188.2	282.2
ZSS500 SR4	1	46.2	30.8	50.0	69.3	ZSS1100 SR6	1	329.3	47.0	141.1	235.2
ZSS500 SR5	1	57.7	19.2	38.5	57.7						

Note: 1. BTO is the opening force, and ETC is the closing force (for valves where the majority of piston rods extend in the closing direction).

2. The output torque in the table does not consider the influence of the piston rod.

3. The piston rod's cross-sectional area has a certain effect on the effective area of the cylinder, which may slightly reduce the theoretical output torque, but the impact is minimal and can be neglected.

4. This table is suitable for top-discharge valves with a normally closed type. For other valves with similar switch directions opposite to the conventional ones, attention should be paid to the selection of air-open and air-close.

5. For some special strokes, the above data may vary. Please refer to the actual inquiry torque.

Double-Acting - Double Cylinder (Series)

Model	Stroke	Air consumption(L)	
		Opening	Closing
ZS160/2C	40	2.6	2.8
	60	3.4	3.6
ZS200	40	4.2	4.4
	60	5.2	5.4
ZS250	40	5.2	5.4
	60	6.6	6.8
	75	7.8	80.0
	110	13.4	13.8
ZS300	40	9.6	9.8
	60	12.6	12.8
	75	14.6	14.8
	110	19.6	19.8
ZS350	40	13.4	13.6
	60	17.2	17.4
	75	20.0	20.2
	110	26.6	27.0
ZS400	75	26.2	26.4
	110	34.8	35.2
	155	46.2	46.4
ZS450	75	33.2	33.4
	110	44.2	44.6
	155	58.4	58.8
ZS500	75	41.0	41.2
	110	54.6	55.0
	155	72.2	72.6
	230	101.6	102.0
ZS550	75	49.6	50.0
	110	66.2	66.6
	155	87.6	88.0
	230	123.0	123.4

Model	Stroke	Air consumption(L)	
		Opening	Closing
ZS600	75	59.2	59.6
	110	78.8	79.2
	155	104.2	104.6
	230	146.4	147.0
ZS700	75	80.6	81.0
	110	107.4	107.8
	155	142.0	142.4
	230	199.6	200.0
	280	242.0	243.0
ZS800	75	105.4	105.6
	110	140.4	140.6
	155	185.6	186.0
	230	260.8	261.2
	280	310.8	311.4
ZS900	75	133.4	133.6
	110	178.0	178.4
	155	235.0	235.6
	230	330.2	330.6
	280	393.6	394.2
ZS1000	75	164.8	165.0
	110	219.6	220.0
	155	290.0	290.4
	230	407.6	402.4
	280	486.2	486.8
ZS1100	75	199.2	199.6
	110	265.6	266.0
	155	350.0	351.4
	230	493.4	494.0
	280	588.4	590.0



Double Acting - Single Cylinder

Model	Stroke	Air consumption(L)
ZS125	30	0.6
	60	0.9
ZS160	30	1.1
	70	1.9
ZS200	40	2.1
	70	3.0
	110	4.3
ZS250	40	3.4
	110	6.8
	130	7.9
ZS300	60	6.3
	155	12.9
	130	11.2
	180	14.6
ZS350	60	8.6
	180	20.0
	230	24.7
ZS400	100	16.1
	180	26.2
	230	32.4
	280	38.9
ZS450	100	20.6
	230	41.1
	280	49.0
	330	57.4
ZS500	150	35.2
	280	60.5
	330	70.0
	380	80.1
	430	89.8

Model	Stroke	Air consumption(L)
ZS550	150	42.6
	380	97.0
	430	108.8
	480	120.6
ZS600	200	64.8
	430	129.0
	480	143.6
	530	157.6
ZS700	200	88.0
	480	195.7
	530	214.0
	630	253.0
ZS800	200	115.0
	530	280.0
	630	330.0
	730	381.0
ZS900	250	177.0
	630	419.0
	730	482.0
	850	558.0
ZS1000	300	258.0
	730	595.0
	850	690.0
	950	768.0
ZS1100	300	313.0
	850	835.0
	950	929.0
	1050	1024.0

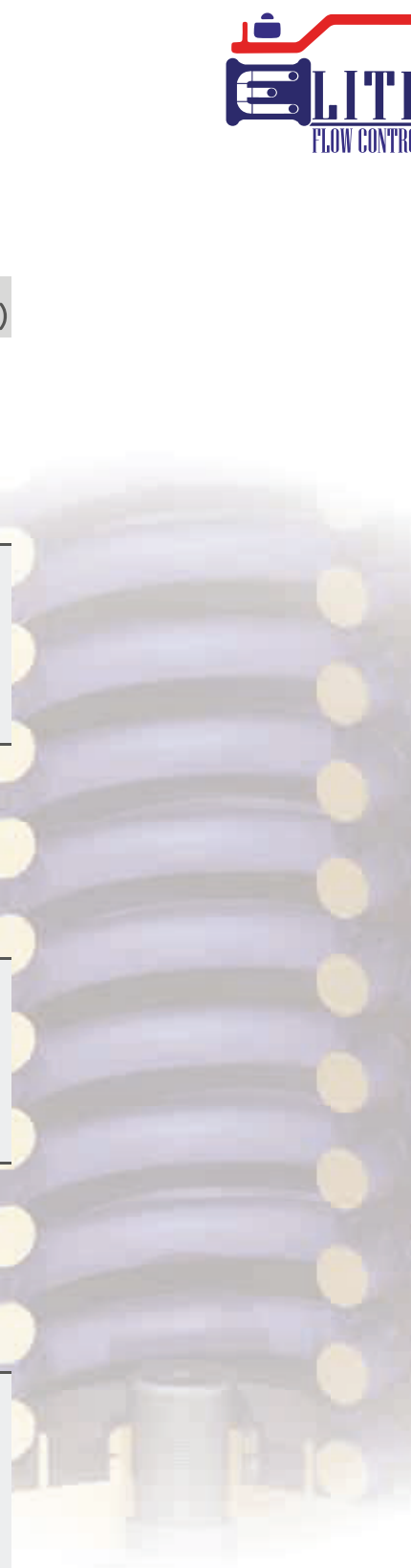

Overall Dimensions Outline Dimensions – without Bracket

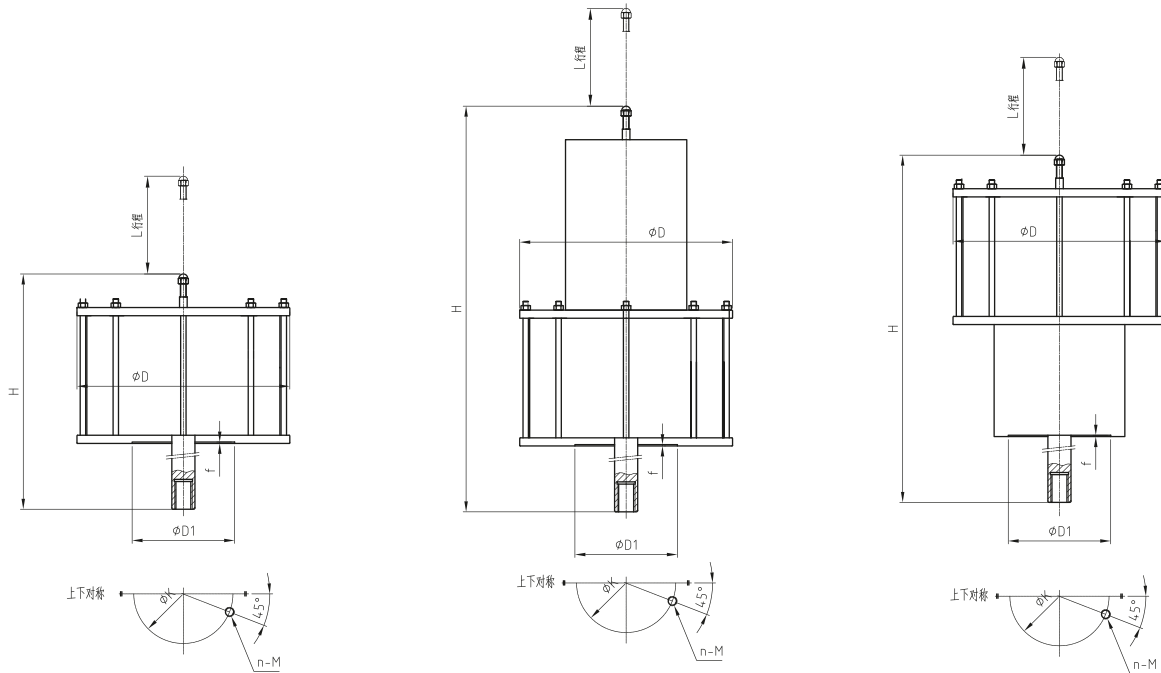

Cylinder diameter	D	D1	H	f	K	N-M	Flange connection ISO5211	P Air source interface	Weight kg
125	190	55	Different strokes have different heights, please contact Elitegocl for details.	4	70	4-M8	F07	G1/4"	
160	225	55		4	70	4-M8	F07	G1/4"	
200	265	70		4	102	4-M10	F10	G1/4"	
250	320	85		4	125	4-M12	F12	G1/4"	
300	375	100		5	140	4-M16	F14	G3/8"	
350	420	130		6	165	4-M20	F16	G3/8"	
400	480	130		6	165	4-M20	F16	G3/8"	
450	525	200		6	254	8-M16	F25	G3/8"	
500	580	230		6	298	8-M20	F30	G1/2"	
550	640	230		6	298	8-M20	F30	G1/2"	
600	703	230		6	298	8-M20	F30	G1/2"	
700	803	260		6	356	8-M30	F35	G1"	
800	913	260		6	356	8-M30	F35	G1"	
900	1013	300		9	406	8-M36	F40	G1"	
1000	1130	300	9	406	8-M36	F40	G1"		
1100	1230	370	9	483	12-M36	F48	G1"		

Outline Dimensions - with Top - Mounted Manual

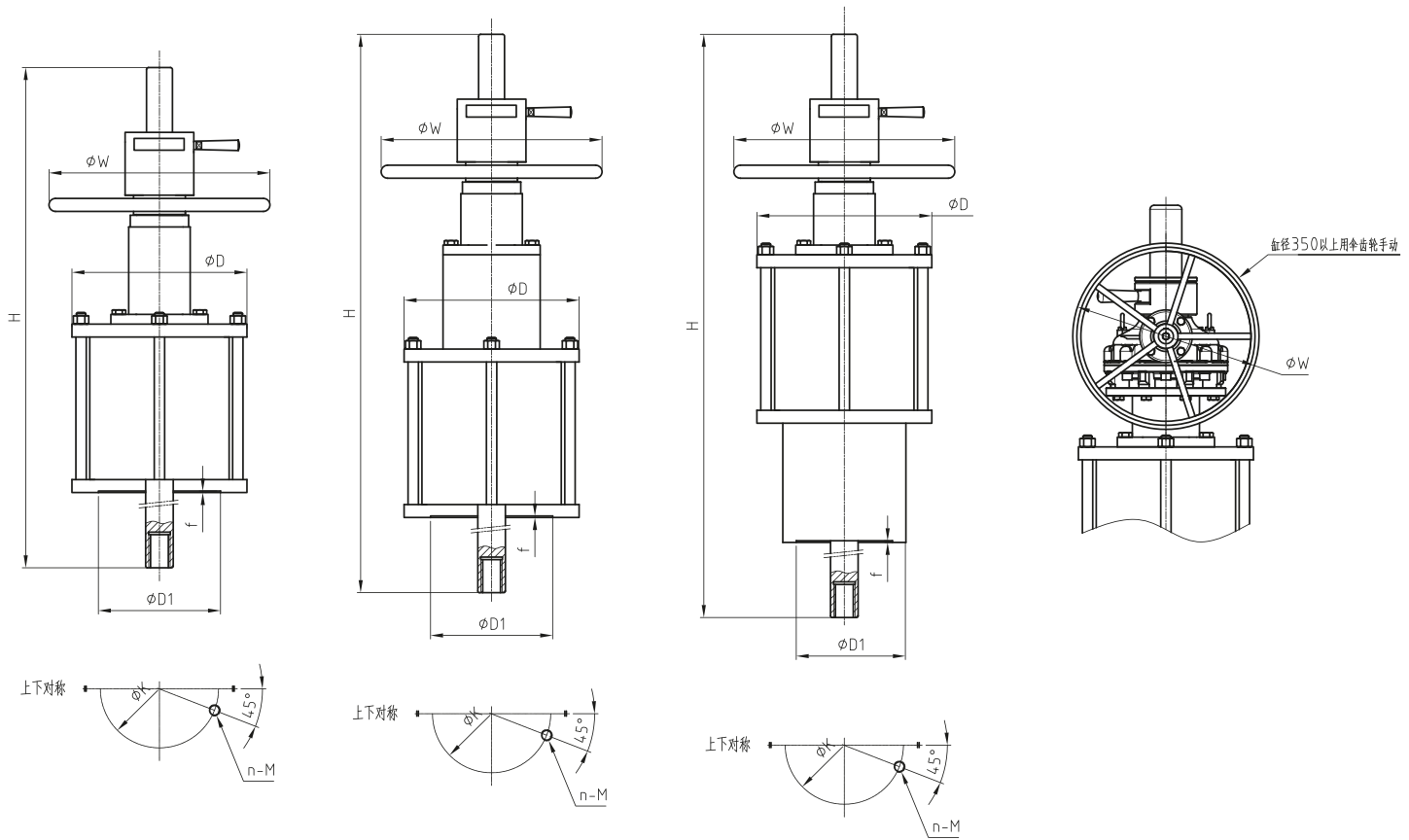

Cylinder diameter	D	D1	H	f	K	N-M	W	Flange connection ISO5211	P Air source interface	Weight kg
200	265	70	Different strokes have different heights, please contact Elitegoc for details.	4	102	4-M10	300	F10	G1/4"	
250	320	85		4	125	4-M12	400	F12	G1/4"	
300	375	100		5	140	4-M16	400	F14	G3/8"	
350	420	130		6	165	4-M20	450	F16	G3/8"	
400	480	130		6	165	4-M20	600	F16	G3/8"	
450	525	200		6	254	8-M16	600	F25	G3/8"	
500	580	230		6	298	8-M20	800	F30	G1/2"	
550	640	230		6	298	8-M20	800	F30	G1/2"	
600	703	230		6	298	8-M20	800	F30	G1/2"	

Outline Dimensions - With center - Mounted Side Manual

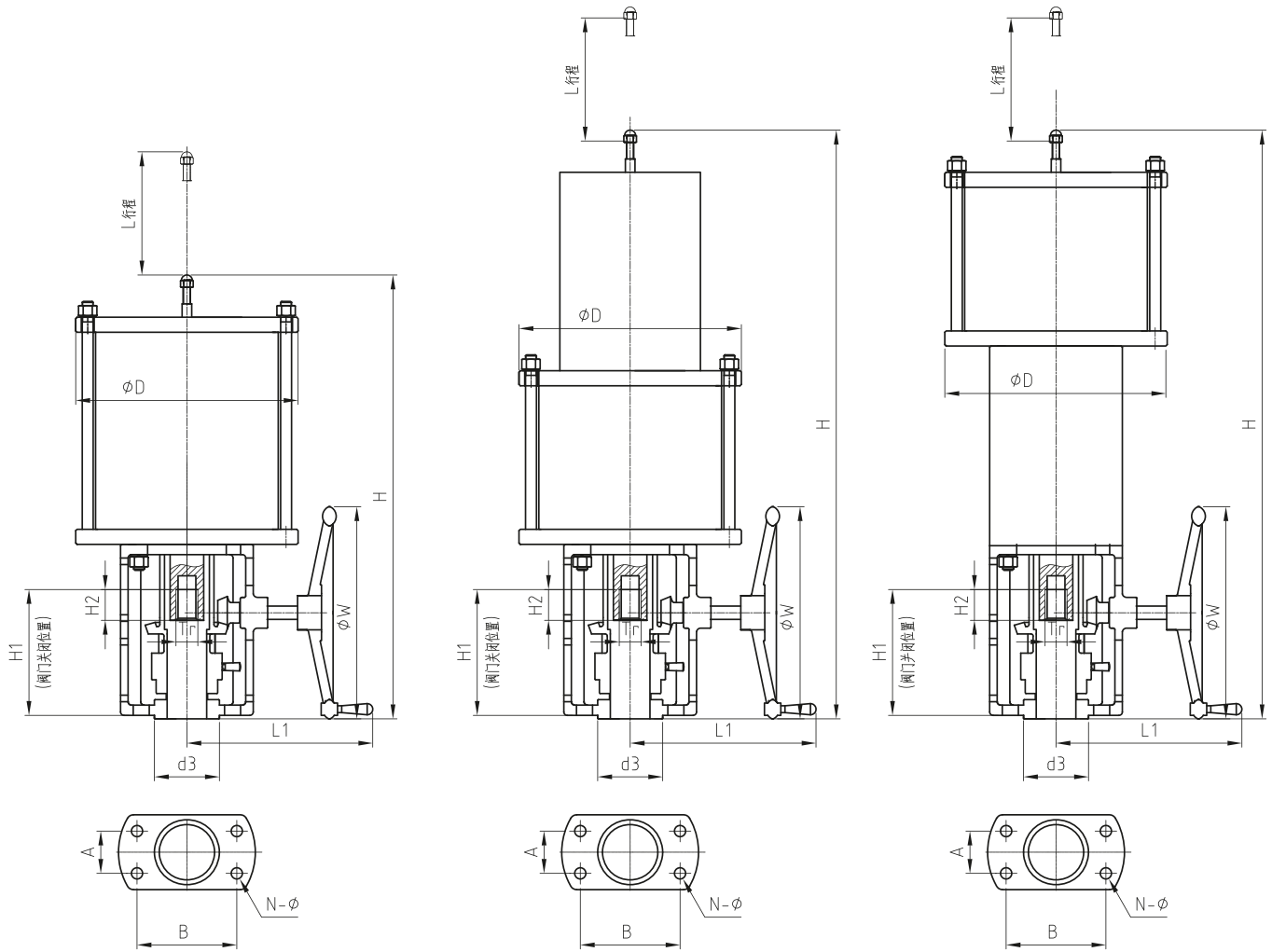

Cylinder diameter	D	A	B	L1	H2	H	H1	d3	f	n-∅	W	P Air source interface	Weight kg
200	265	90	100	251	Tx2	Different strokes have different heights, please contact Elitegoc for details.	139+Tx1.75	95	5	4-∅18	300	G1/4"	
250	320	90	100	272	Tx2		139+Tx1.75	95	5	4-∅18	300	G1/4"	
300	375	90	100	299	Tx2		139+Tx1.75	95	5	4-∅18	350	G3/8"	
350	420	120	165	420	Tx2		184+Tx1.75	120	5	4-∅23	400	G3/8"	
400	480	120	165	420	Tx2		184+Tx1.75	120	5	4-∅23	400	G3/8"	
450	525	120	165	420	Tx2		184+Tx1.75	120	5	4-∅23	500	G3/8"	
500	580	200	210	486	Tx2		240+Tx1.75	170	5	4-∅30	500	G1/2"	
550	640	200	210	548	Tx2		240+Tx1.75	170	5	4-∅30	600	G1/2"	
600	703	200	210	548	Tx2	240+Tx1.75	170	5	4-∅30	600	G1/2"		

Outline Dimensions - Control Valve for Globe Valve

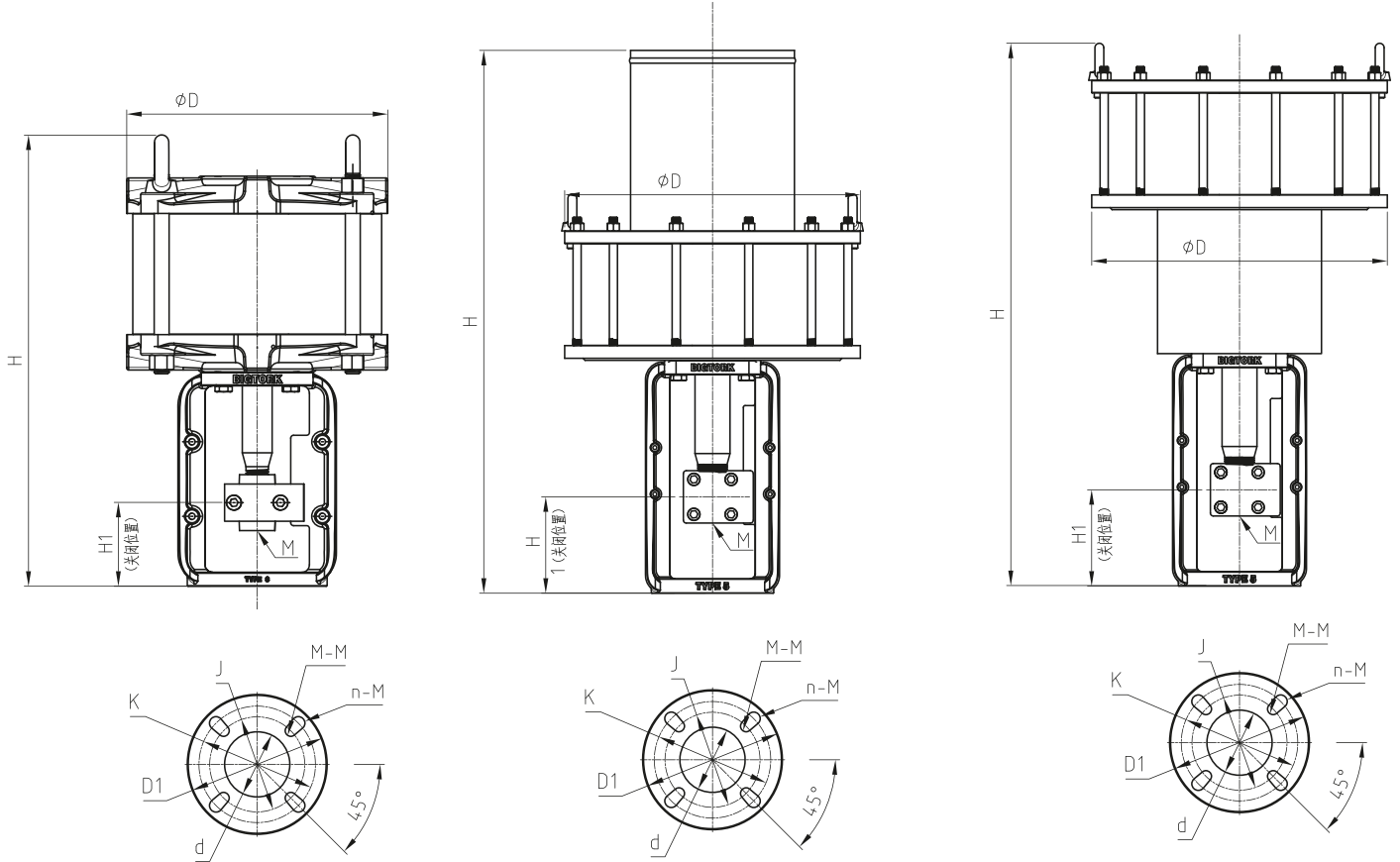

Cylinder diameter	D	D1	H	H1	J	d	k	M-m	n-m	Flange connection ISO5211	P Air source interface	Weight kg
200	265	150	Different strokes have different heights, please contact Elitegoc for details.	85	102	70	125	4-Ø12	4-Ø14	F10/F12	G1/4"	
250	280	150		85	102	70	125	4-Ø12	4-Ø14	F10/F12	G1/2"	
300	330	150		85	102	70	125	4-Ø12	4-Ø14	F10/F12	G1/2"	
350	420	175		105	125	85	140	4-Ø14	4-Ø18	F12/F14	G1/2"	
400	480	175		105	125	85	140	4-Ø14	4-Ø18	F12/F14	G1/2"	
450	525	210		165	140	100	165	4-Ø18	4-Ø22	F14/F16	G3/4"	
500	580	210		165	140	100	165	4-Ø18	4-Ø22	F14/F16	G3/4"	
550	640	210		165	140	100	165	4-Ø18	4-Ø22	F14/F16	G3/4"	
600	703	210	165	140	100	165	4-Ø18	4-Ø22	F14/F16	G1"		

Outline Dimensions – Control Valve for Globe Valve with top-mounted Manual

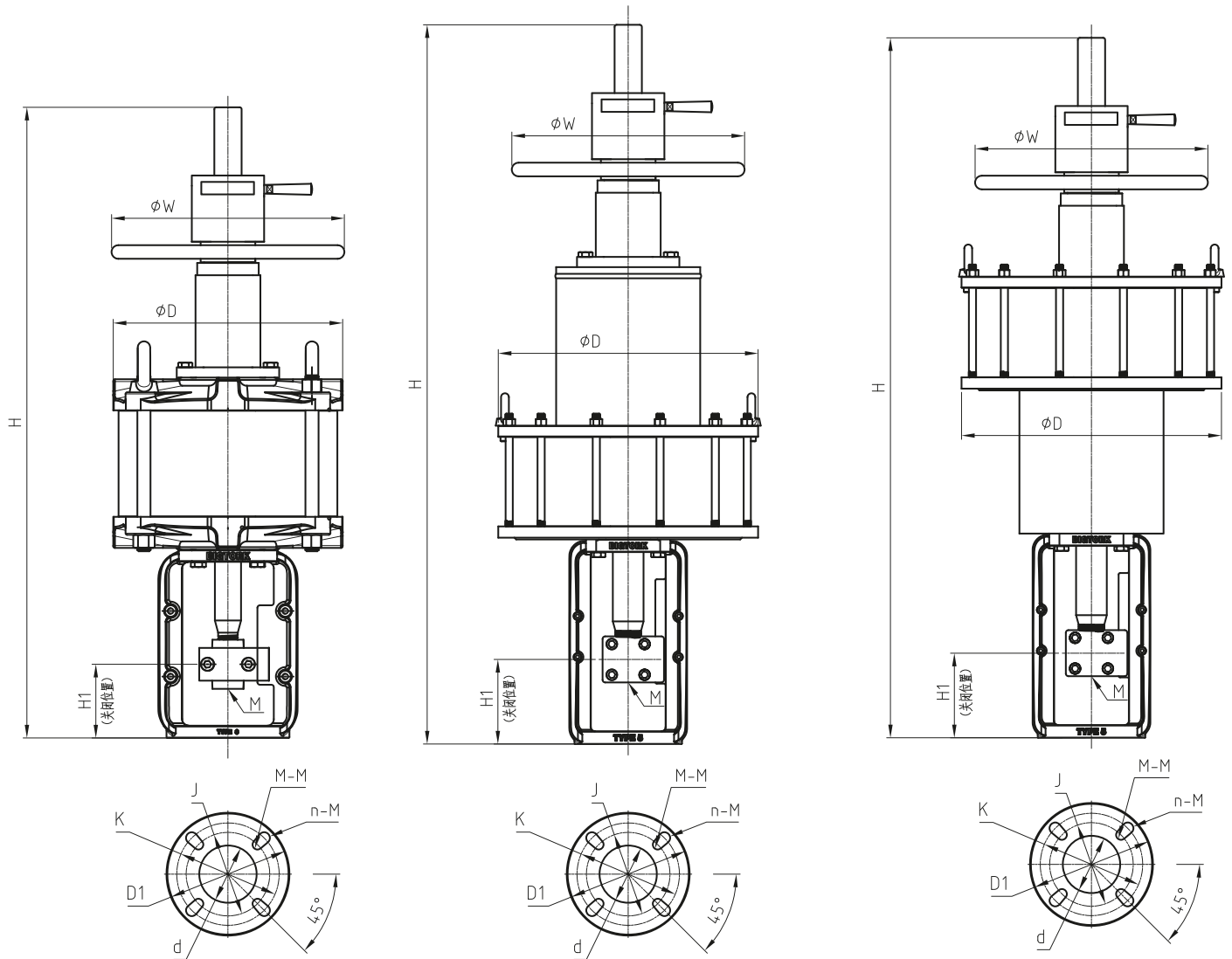

Cylinder diameter	D	D1	H	H1	J	d	k	M-m	n-M	W	Flange connection ISO5211	P Air source interface	Weight kg
200	265		Different strokes have different heights, please contact Elitegod for details.	85	102	70	125	4- ϕ 12	4- ϕ 14	300	F10/F12	G1/4"	
250	280	150		85	102	70	125	4- ϕ 12	4- ϕ 14	400	F10/F12	G1/2"	
300	330	150	85	102	70	125	4- ϕ 12	4- ϕ 14	400	F10/F12	G1/2"		
350	420	175	105	125	85	140	4- ϕ 14	4- ϕ 18	450	F12/F14	G1/2"		

Outline Dimensions - Control Valve for Globe Valve with handwheel gearbox

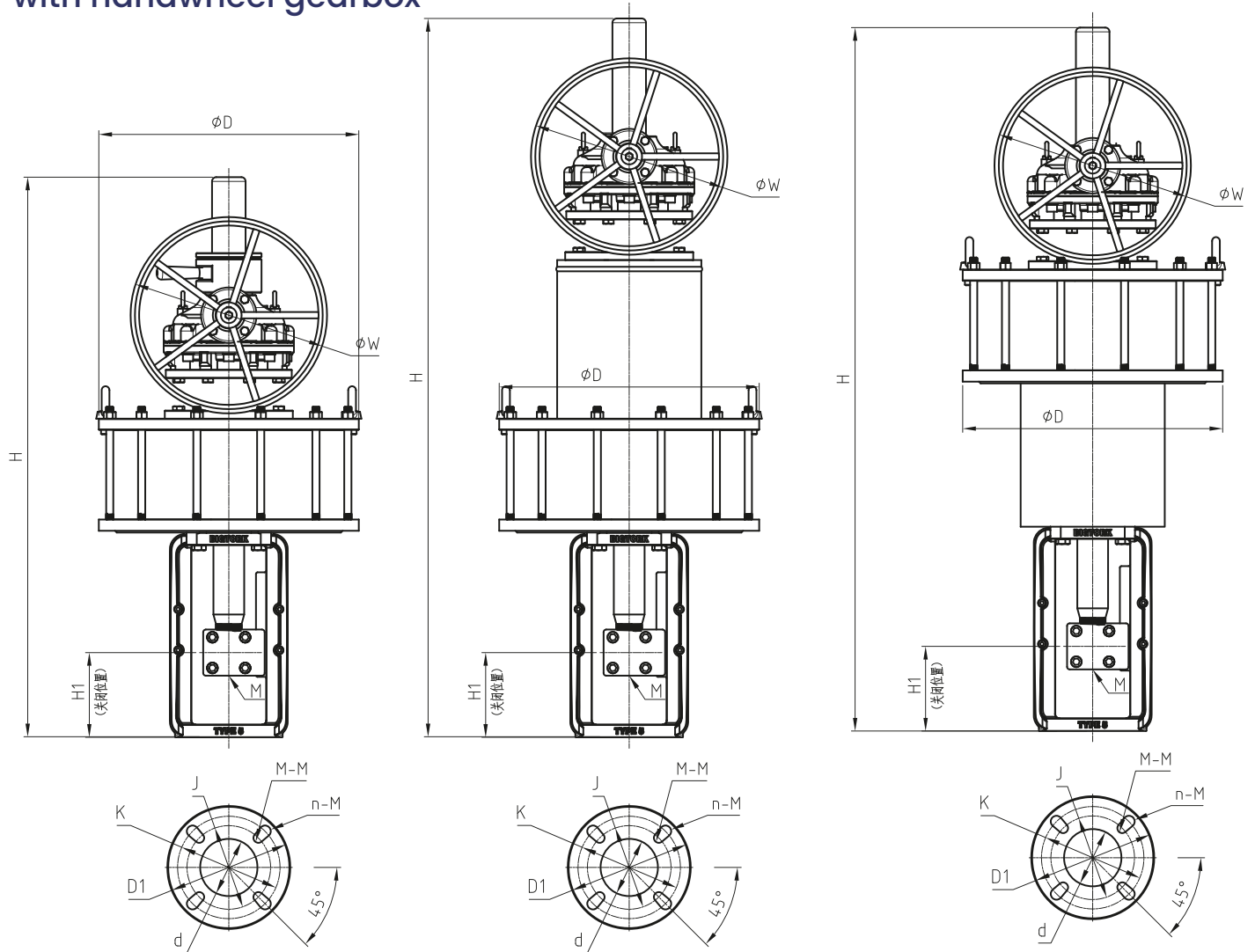

Cylinder diameter	D	D1	H	H1	J	d	k	M-m	n-M	W	Flange connection ISO5211	P Air source interface	Weight kg
350	420	175	Different strokes have different heights, please contact Eltego for details.	105	125	85	140	4- ϕ 14	4- ϕ 18	450	F12/F14	G1/2"	
400	480	175		105	125	85	140	4- ϕ 14	4- ϕ 18	600	F12/F14	G1/2"	
450	525	210		165	140	100	165	4- ϕ 18	4- ϕ 22	600	F14/F16	G3/4"	
500	580	210		165	140	100	165	4- ϕ 18	4- ϕ 22	800	F14/F16	G3/4"	
550	640	210		165	140	100	165	4- ϕ 18	4- ϕ 22	800	F14/F16	G3/4"	
600	703	210	165	140	100	165	4- ϕ 18	4- ϕ 22	800	F14/F16	G1"		

Explanation of the Preparation of the Ordering Model

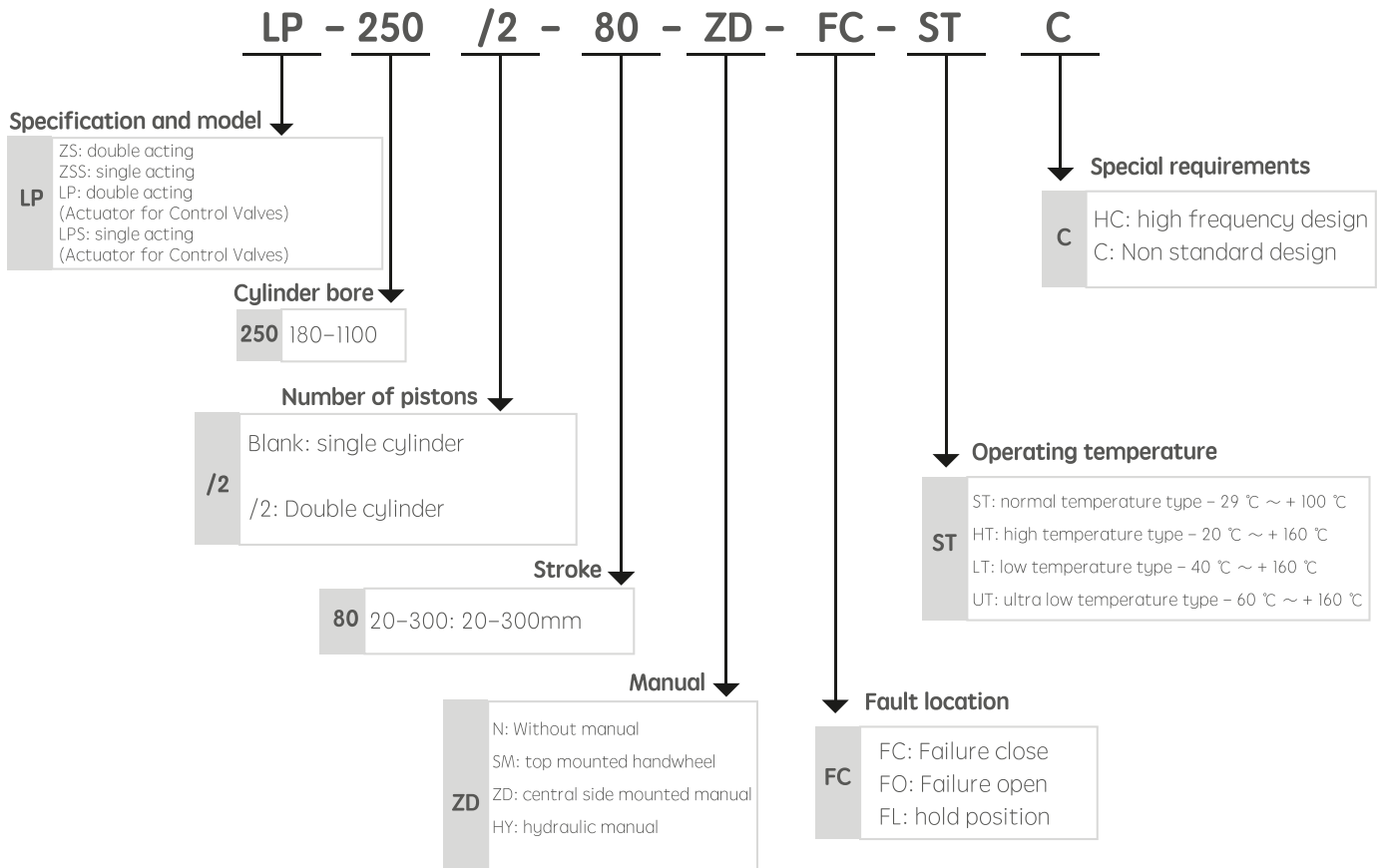

Order Information

Application Conditions:

1. Switch or control regulation adjust control
2. Input signal range
3. Maximum air supply pressure
4. Valve body type and size used in conjunction with the actuator
5. Valve stem travel

Actuator and Positioner:

1. Specify actuator model
2. Determine if positioner is required
3. Determine if top-mounted handwheel is required

Cylinders and Accessories:

1. For ordering information, refer to separate valve body product cylinder samples and accessory product samples.

6. Actuator thrust required for full extension and full retraction of the actuator push rod
7. Specify required operating time if critical
8. Specify seismic requirements if critical
9. Ambient temperature range

4. Determine if adjustable up or down travel limiters are required
5. Refer to technical specifications and indicate your options where choices must be made.

Special Specification – Related Accessories

Elitegocl Company can provide actuating mechanisms of various specifications and special requirements according to user demands. These requirements include special motion functions, unique connection methods, extended travel range, rapid motion, and requirements with buffering, among others. Specific requirements can be discussed with our company when placing an order.

The diagram on the right shows a lifting and +90° rotating compound motion actuating mechanism. This product can be applied to track-type ball valves, achieving a certain lifting travel distance first to disengage the valve from the seat, and then rotating 90° to open the valve. The closing action is the opposite of the opening action.

The purpose is to achieve frictionless opening and closing of the valve seat and valve core, providing extended valve service life and reducing operating torque.

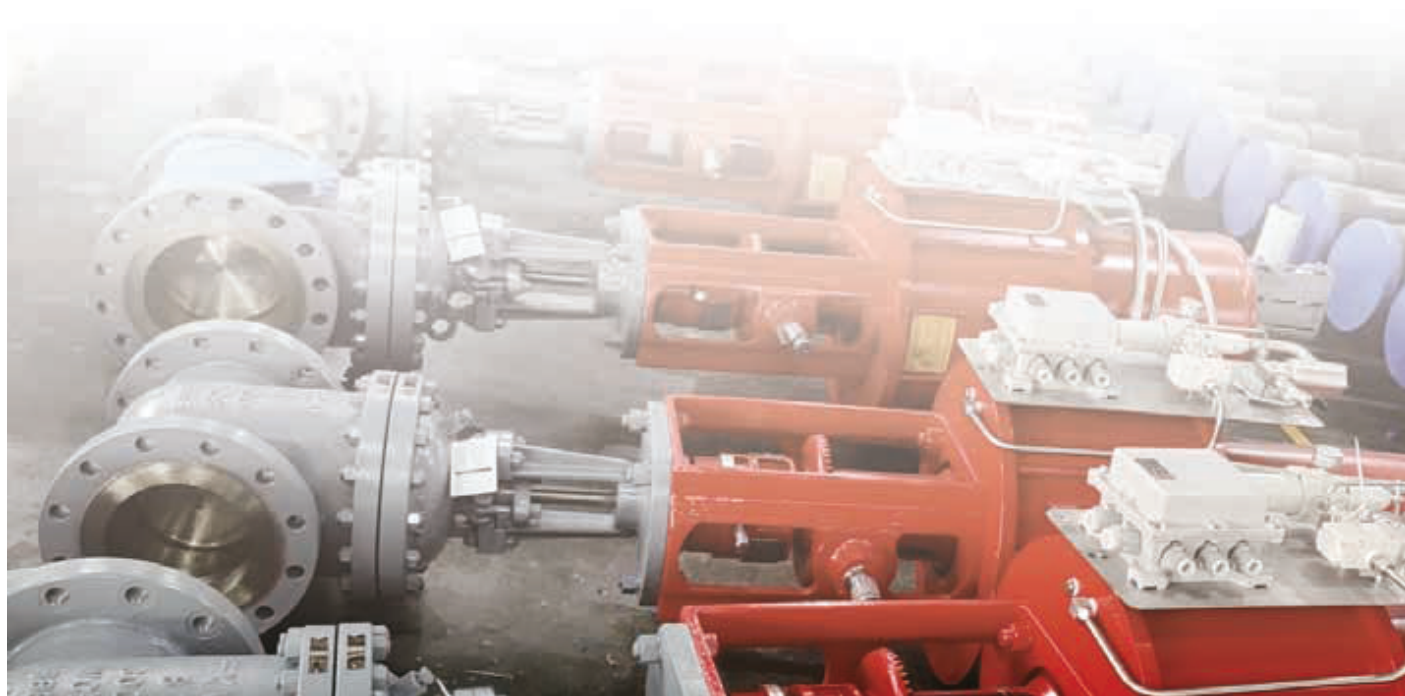
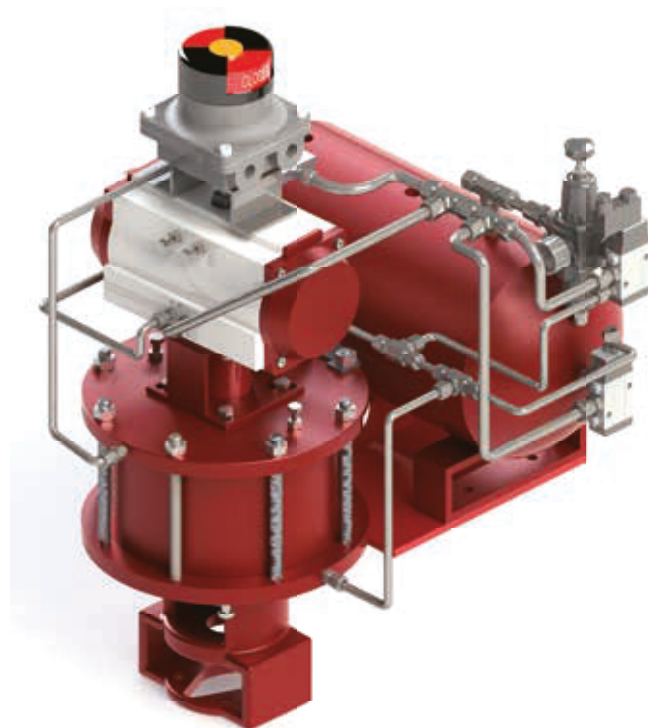

HOW TO AVOID PROBLEMS

- Ball valves shall be transported and stored with the ball in the fully open position.
- Flanged ends and welded ends shall be protected.
- End protection shall be removed only when the valve is installed in the line.
- Valves shall be handled using the proper lifting lugs.
- Valves shall be stored according to Elite storage procedures. Long term storage shall be avoided.
- For welded-end valves, advise Elite if there will be a post weld heat treatment (transition pups may be necessary to avoid damages to seals).
- Flush and clean the line before operating the valve.
- Make sure no line-testing fluid is left in the line and/or the valve body.
- Avoid leaving the valve body filled with salt water to prevent internal corrosion.
- During line-testing, valves shall be left in the partially open position for the minimum possible amount of time.
- Standard ball valves shall be used for on-off service only. Throttling service (use of the valve with the ball partially open) can damage the seats.
- Make sure to take into consideration the actual service conditions when selecting materials for O-rings and seat inserts.
- Always specify anti-explosive decompression material for valves to be used in high pressure gas service.
- Make sure the selected actuator has been properly sized (an oversized actuator can be as dangerous as an undersized one).
- Advise Elite of cycle frequency to ensure proper sizing of actuator.
- Do not use the actuator to lift the valve.

◀ WARRANTY CLAUSE

Elite Flow Control products are delivered with a standard guarantee of good performance for the period of 18 months after the delivery date or 12 months of operation after commissioning.

Warning: The scope of Warranty is covered for manufacturing defects only. In case the valve failure is due to the wrong operations by the customer the warranty is not applicable.

In order to claim the warranty due to the manufacturing defects, the customer needs to prepare the detailed rejection report including the inspection procedure, operational report, pictures of valves, if this report proves that the fault is due to the manufacturing defect, Elite will provide the appropriate solution.



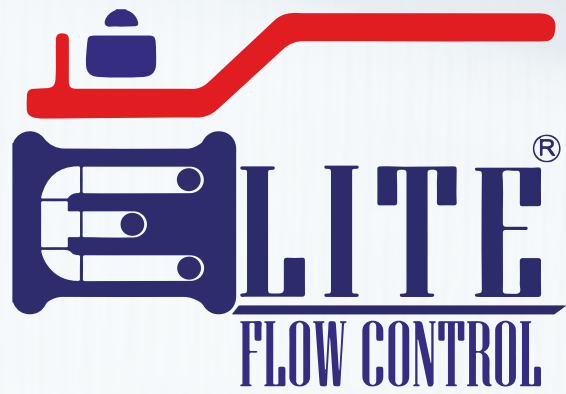

WE CONTROL THE FLOW

Elite Flow Control USA LLC

13220 Murphy Road, Unit #100

Stafford, TX 77477

United States of America

Tel: 832-987-1774 / 832-539-6968

Email: contact@elitegoocl.com

Web: www.eliteflowusa.com

www.elitegoocl.com

