

WE CONTROL THE FLOW

Elite provides comprehensive Valve, Automation Packages, and Instrumentation solutions for all industrial applications, ensuring optimal control of fluid flow with our expertise: "We control the flow."



Elite Flow Control USA LLC
www.eliteflowusa.com

COMPANY PROFILE

Elite provides comprehensive Valve, Automation Packages, and Instrumentation solutions for all industrial applications, ensuring optimal control of fluid flow with our expertise: "We control the flow."

Elite Flow Control is one of the leading and renowned brand of Valves having its own independent manufacturing facilities and global existence in the United States of America, United Kingdom and China.

Our design and manufacturing range includes Ball Valves, Gate Valves, Globe Valves, Check Valves, Plug Valves, Butterfly Valves, Control Valves, Actuated Valves, and have a dedicated PTFE / PFA lining facility for PTFE / PFA Lined Valves, Pipe Spools, Pipe fittings, and associated equipment for high corrosive/chemical applications.

MISSION

ELITE FLOW CONTROL FOCUSED TO PROVIDE THE SUPERIOR QUALITY VALVES AT COMPETITIVE PRICES TO ITS CUSTOMERS AROUND THE WORLD BY UTILIZING THE COMPANY'S HUMAN RESOURCES AND ADVANCED TECHNOLOGY EQUIPMENT WITH THE STRONG COMMITMENT TO R&D, HEALTH, SAFETY, ENVIRONMENT AND COMPANY'S CORE VALUES.

VISION

TO MAKE OUR BRAND "THE FIRST CHOICE OF CUSTOMERS".

Elite Philosophy

Elite operates on philosophy to provide Immediate Response, Excellent Quality Services, Quick Delivery and Customer Satisfaction followed by our Core Values "What we commit, we deliver" based on this we are having satisfied customers in more than 25 countries and ever expanding throughout the world.

Design Standards

AT series pneumatic actuators are designed and developed on the basis of cutting-edge technology, materials, process, and innovative concept. This configuration incorporates the following features :

- Compliant with ISO5211, DIN3337, VDI/VDE3845, NAMUR standard
- Replaceable on either double acting or spring return actuator for their same exterior size
- Pre-compressed spring easy to install and disassemble
- Piston and end caps in extruded cast aluminium, with high strength and light weight
- Sealing material options for different temperature available
- Part-turn/rotary (e.g.120, 135C, 180c) and multi-turn actuator options available
- Intake port as standard, directly mounting to solenoid valve

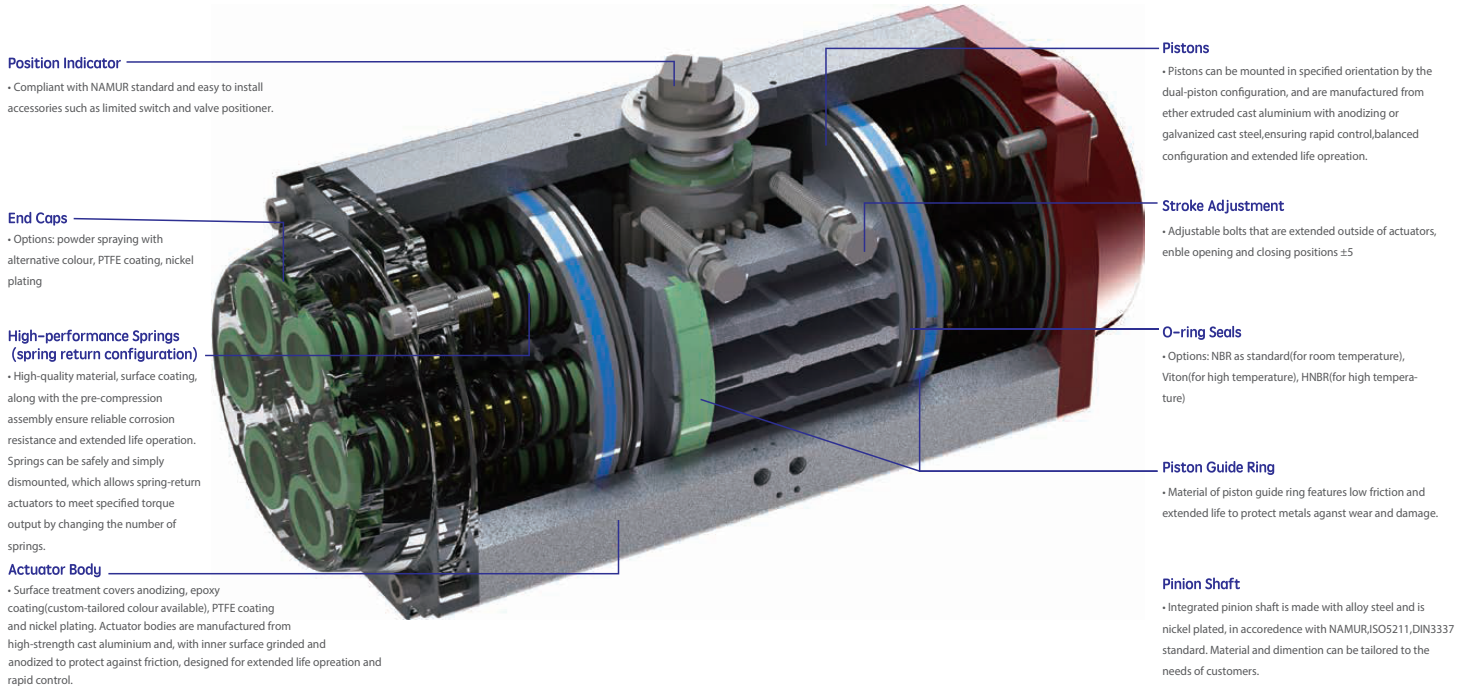

Construction

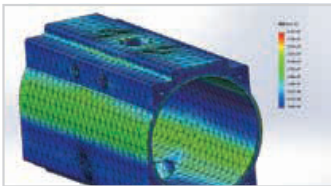

Actuator strength analysis



Stress of pistons analysis



Pinion shaft analysis

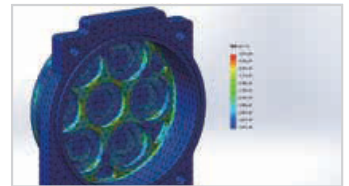

Design standards

- Compliant with EN15714.3, ISO5211, DIN3337, VDI/VDE3845, NAMUR standard

Operating medium

- Dry clean or inert gas, as well as non-corrosive gas unreacted with actuator parts and lubricants
- Dew point temperature: +20
- Particulate matter: $< 30\mu$ ($< 5\mu$ while using positioner)

Air supply pressure

- 3bar
- 4bar
- 5bar (Default Value)
- 6bar

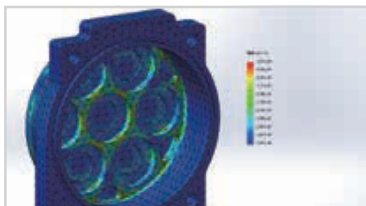

End cap analysis

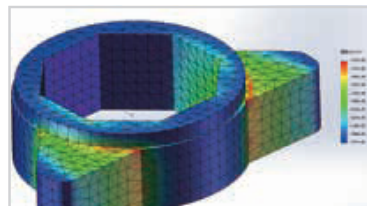

Positioning block analysis



Piston analysis

Air supply pressure

- 3bar
- 4bar
- 5bar (Default Value)
- 6bar

Operating temperature ranges

- Std.: -20 to +80 (-4 to +176)
- Low Temp.: -40 to +80 (-40 to +176)
- Ultra-low Temp.: -60 to +80 (-76 to +176)
- High Temp.: -20 to +160 (-4 to +320)

Lubrication

- Lubricated as standard
- Optional lubricants for high and low temperatures available

Parts and Materials List

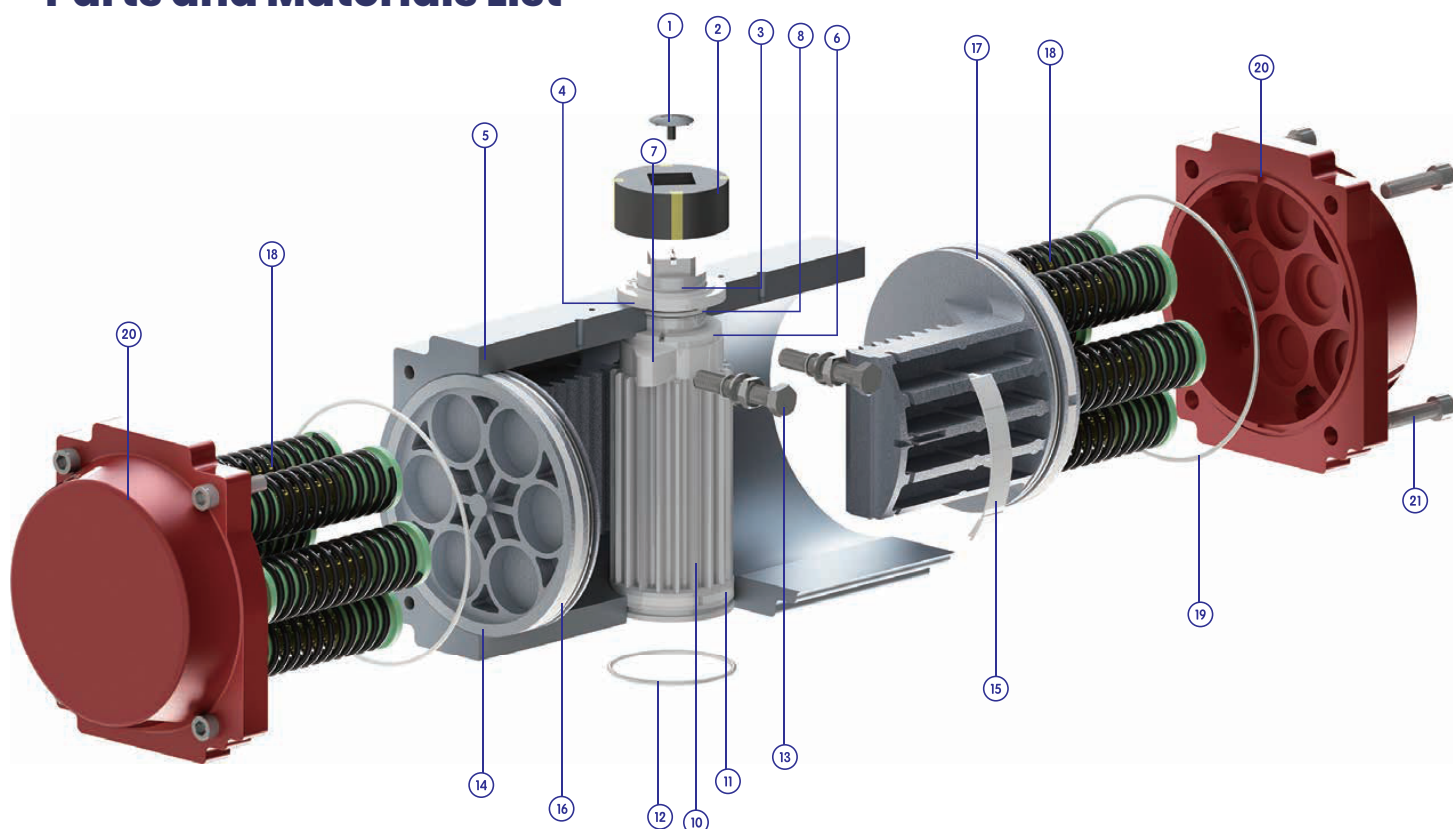

Anti-Corrosion Grade

Parts	Corrosion Protection Class	
	A	B
Actuator body	Anodizing	Teflon coating & anodizing
End cap	Metal polyester coating	Teflon coating
Pinion shaft	Nickel plating on carbon steel	Nickel plating on carbon steel, or stainless steel
Operating environment	General environment	General or slightly acidic environment

- 1 Indicator screw
1pc, plastic
- 2 Indicator
1pc, plastic
- 3 Circlip
1pc, stainless steel
- 4 Gasket
1pc, stainless steel
- 5 Actuator body
1pc, cast aluminium with anodizing, etc.
- 6 Inner gasket
1pc, engineering plastics
- 7 Stroke cam
1pc, Steel
- 8 O-Ring(top pinion)
1pc, NBR (Viton/HNBR optional)
- 9 Bearing(top pinion)
1pc, engineering plastic
- 10 Pinion shaft
1pc, steel with nickel plating (stainless steel optional)
- 11 Bearing(bottom pinion)
1pc, engineering plastics
- 12 O-Ring(bottom pinion)
1pc, NBR (Viton/HNBR optional)
- 13 Stroke bolt
2pcs, stainless steel
- 14 Plug
2pcs, cast aluminium with anodizing/galvanization (cast steel/stainless steel optional)
- 15 Piston guiding ring
2pcs, engineering plastics
- 16 Piston bearing
2pcs, engineering plastics
- 17 Piston seals
2pcs, NBR (Viton/HNBR optional)
- 18 Springs
0-12pcs, spring steel
- 19 End cap seals
2pcs, NBR (Viton/HNBR optional)
- 20 End caps
2pcs, cast aluminium with powder coating, etc.
- 21 End cap bolts
8pcs, stainless steel

Sizing Of Actuators & Torque Characteristics

- Safety factors of valve should be considered in selection of actuator model.
 - Recommended safety factor: 20% (valve for high lubricity clean fluids)
 - Recommended safety factor: 25% (valve for steam or liquid without lubricity factor)
 - Recommended safety factor: 30% (valve for slurry)
 - Recommended safety factor: 40% (valve for dry gases)
 - Recommended safety factor: 60% (valve for powder particles)
- *The above safety factors are supplied for informative

Sample Of Double-Acting Sizing

When sizing a Double-Acting actuator for a ball valve with a given torque 200Nm, which is serving for steam, the recommended safety factor 25% will be applied to the valve torque. Based on the multiplier, the sizing torque will be $200\text{Nm} \times 1.2 = 250\text{ Nm}$. According to the torque sheet of Double-acting actuator, at air supply 0.5MPa for instance, AT125DA supplies more torque than 250NM(254.9Nm). This is suitable to operate the ball valve.

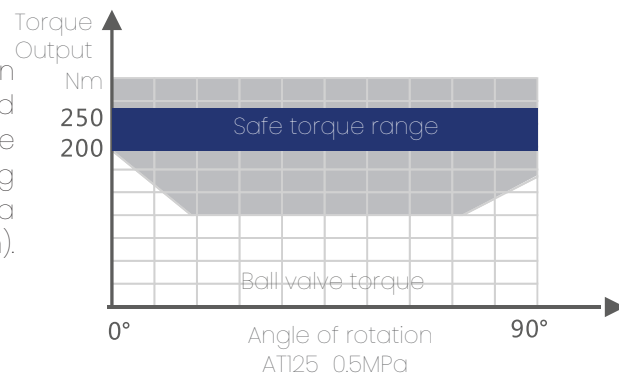

Sample Of Spring-Return Sizing

When sizing a Spring-Return actuator on a butterfly valve with a given torque 100Nm, which is used for dry gases, the recommended safety factor 40% will be applied to the valve torque. Based on the multiplier, the sizing torque will be $100\text{Nm} \times 1.4 = 140\text{ Nm}$. According to the torque sheet of Spring-return actuator, at air supply 0.5MPa for instance, torque 172Nm in the "spring end" torque column is suitable. In addition, valve torque must be covered by both air supply torque and spring end torque. Thus size AT140SR with 10 springs is the first actuator that supplies more torque (172Nm in air supply torque, 168Nm in spring end torque), and is suitable to operate the butterfly valve.

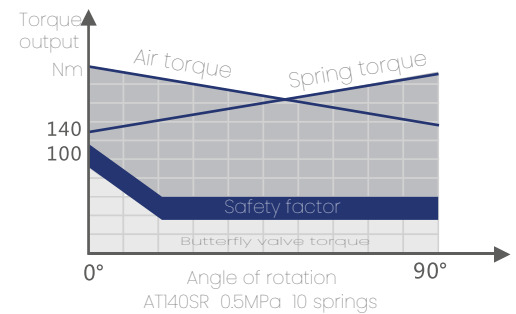

Ordering Instructions

Based on a wealth of experience, Elite has the knowledge to provide reliable and appropriate automotive solutions for valve applications.

General technical attributes for product selection include:

- Valve: valve type, operating pressure, valve size, sealing type (hard sealed and soft sealed options), media and operating temperature
- Double-acting and spring-return configurations (normally closed and normally open options)
- Solenoid valve type: double-solenoid/single-solenoid, supply voltage, explosionproof type
- Limited switches type: basic/explosionproof type
- Valve positioner type: current signal, air supply signal, electric-pneumatic converters, explosionproof grade
- Air filter & regulator
- Manual gear operator
- Customised solutions
- Accessories of designated brand

Working Principle of Double-Acting Actuator

The air supply pressure from the port "2" forces the two pistons to move towards either end of the cylinder. Then it is exhausted out of the port "4", which allows the pinion shaft driven by the two piston racks to turn counter-clockwise.

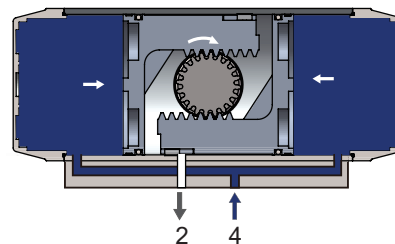

In contrast, the air supply pressure from the port "4" forces the two pistons to move towards the middle of the cylinder.

Then it is exhausted out of the port "2", which allows the pinion shaft driven by the two piston racks to turn clockwise.

Note: If the pistons are mounted in the opposite direction of above, the pinion shaft turns counterclockwise.

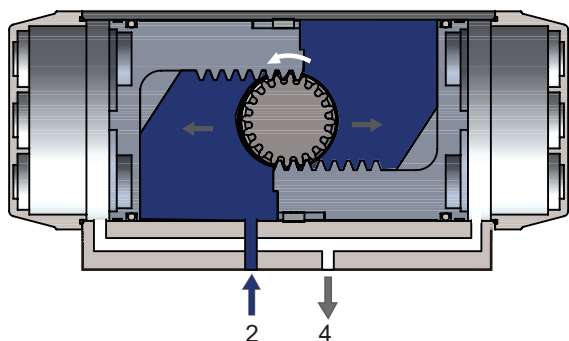

Torque output (Unit: NM) - Double-acting actuators

Model	Input air supply (Unit: bar)					
	3.0	4.0	5.0	6.0	7.0	8.0
AT032	4.6	6.1	7.6	9.2	10.7	12.2
AT052	12	16	20	24.0	25	32
AT063	21.7	28.9	36.1	43.4	50.6	57.8
AT075	30	40	50	60	70	80.1
AT083	46	61.3	76.6	92	107.3	122.6
AT092	67.6	90.1	112.6	135.2	157.7	180.2
AT105	98	130	163	196	228	261
AT125	153	204	255	306	357	408
AT140	261	348	435	521	608	695
AT160	397	530	662	794	927	1059
AT190	640	854	1067	1280	1494	1707
AT210	880	1173	1466	1760	2053	2346
AT240	1379	1839	2298	2758	3218	3677
AT270	1939	2586	3232	3878	4525	5171
AT300	2572	3430	4288	5145	6003	6860
AT350	3837	5115	6394	7673	8952	10231
AT400	5488	7318	9148	10977	12807	14636

Torque diagram - Double-acting actuators

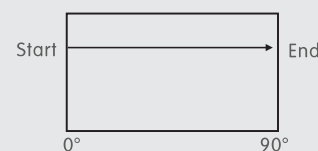

Torque diagram - Spring-return actuators

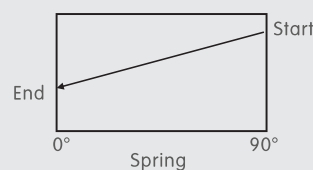
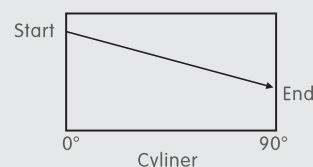

Working Principle of Double-Acting Actuator

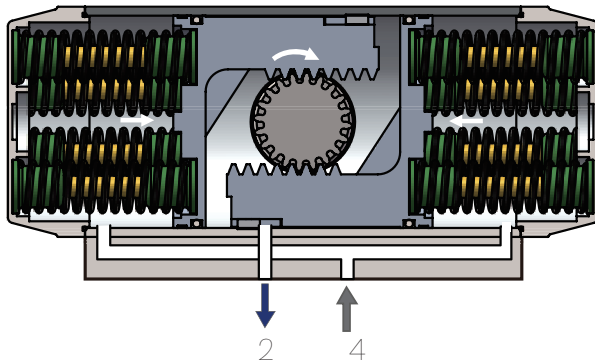

After the air supply pressure is reversed by the solenoid valve, the springs force the pistons to move towards the middle of the cylinder. Then the air is exhausted out of the port "2", which allows the pinion shaft driven by the two piston racks to turn clockwise.

Note: If the pistons are mounted in the opposite direction of above, the pinion shaft turns counter-clockwise.

The air supply pressure from the port "4" forces the two pistons to move towards either end of the cylinder, from which the springs set in both directions are compressed. Then the air is exhausted out of the port "2", which allows the pinion shaft driven by the two piston racks to turn counterclockwise.

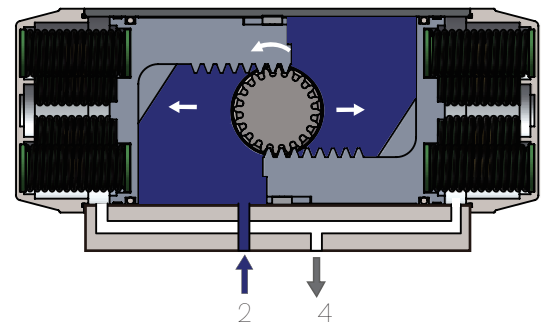

Torque Output (Unit: NM) - Spring-Return Actuators

Torque output(Unit NM) - Spring-return actuators																	Spring torque output	
Model	Spring number	25Bar		3Bar		4Bar		5Bar		6Bar		7Bar		8Bar		90° Start	0° End	
		0° Start	90° End	0° Start	90° End	0° Start	90° End	0° Start	90° End	0° Start	90° End	0° Start	90° End					
AT52SR	5	5.7	3.8	7.6	5.7											6.2	4.3	
	6	4.9	2.5	6.9	4.5	10.9	8.5									7.4	5.0	
	7	4.0	1.3	6.0	3.3	9.8	7.3	14.0	10.4							8.6	5.9	
	8			5.2	2.0	9.2	6.0	13.2	9.1	17.2	14.1					9.9	6.7	
	9			4.3	0.8	8.3	4.8	12.3	7.9	16.3	12.8	20.3	16.8			11.1	7.6	
	10					7.4	3.6	11.5	6.7	15.5	11.6	19.5	15.6			12.4	8.5	
AT63SR	5	11.4	7.7	15.0	11.4	22.3	14.9									10.4	6.8	
	6	10.1	5.7	13.6	9.3	20.9	16.6	28.3	23.9							12.5	8.2	
	7	8.6	3.6	12.5	7.2	19.5	14.5	26.8	21.9							14.6	9.6	
	8			10.9	5.1	18.2	12.4	25.5	19.8	32.8	27.0	40.1	34.3			16.7	10.9	
	9					16.8	10.4	24.1	17.7	31.4	24.9	38.7	32.2			18.8	12.3	
	10					14	8.2	22.8	15.6	30.0	22.8	37.3	30.1	44.7	37.4	20.9	13.7	
AT75SR	5	14.5	10.6	19.4	15.5	29.5	25.7									14.5	10.5	
	6	12.4	7.6	17.3	12.6	27.4	22.7	37.5	32.8							17.4	12.7	
	7	10.4	4.8	15.2	9.7	25.3	19.9	35.4	29.9							20.3	14.8	
	8			13.1	6.8	23.1	16.9	33.3	27.0	43.2	37.0	53.3	47.0			23.2	16.9	
	9					21.0	14.1	34.2	24.1	41.1	34.1	51.2	44.2			26.1	19.0	
	10					19.0	11.1	28.8	21.2	39.0	31.2	49.1	41.2	59.1	51.2	29.0	21.1	
AT83SR	5	23.3	16.1	31.1	24.0	46.8	39.7									23.0	15.8	
	6	20.1	11.5	28.0	19.3	43.7	35.1	59.4	50.7							27.6	19.0	
	7	17.0	6.9	24.8	14.8	40.5	30.5	56.2	46.2							32.2	22.1	
	8			21.7	10.1	37.4	25.8	53.1	41.5	68.8	57.2	84.5	72.9			36.8	25.3	
	9					34.2	21.3	49.9	37.0	65.6	52.6	81.2	68.3			41.4	28.5	
	10					31.0	16.6	46.7	32.3	62.4	48.0	78.1	63.7	93.8	79.3	46.0	31.6	
AT83SR	11					43.6	27.7	59.3	43.4	75.0	59.1	90.6	74.8			50.6	34.8	
	12					40.4	23.2	56.1	38.9	71.7	54.5	87.4	70.0			55.2	38.0	

Torque Output(Unit: NM) – Spring-Return Actuators

Torque output(Unit: NM) – Spring-return actuators																Spring torque output	
Model	Spring number	2.5Bar		3Bar		4Bar		5Bar		6Bar		7Bar		8Bar		90° Start	0° End
		0° Start	90° End	0° Start	90° End	0° Start	90° End	0° Start	90° End	0° Start	90° End	0° Start	90° End	0° Start	90° End		
AT92SR	5	33.1	22.0	44.2	33.2	66.8	55.9									34.4	23.3
	6	28.4	15.2	39.6	26.4	62.2	49.0	84.8	71.6							41.2	28.0
	7	23.8	8.2	34.9	19.4	57.5	42.1	80.2	64.7							48.1	32.7
	8			31.3	12.6	52.9	35.2	75.5	57.9	98.1	80.5	120.7	103.0			55.0	37.3
	9					48.2	28.4	70.9	51.0	93.5	73.6	116.0	96.1			61.9	42.0
	10					43.6	21.5	66.2	44.1	88.8	66.7	111.3	89.2	134.0	111.8	68.7	46.7
	11							61.5	37.2	84.1	59.9	106.6	82.4	129.2	105.0	75.6	51.4
12							50.8	30.4	79.4	53.0	101.9	75.5	124.5	98.1	82.5	56.0	
AT105SR	5	51.0	33.4	67.5	49.9	100.6	83.0									49.2	31.6
	6	44.7	23.5	61.1	40.0	94.2	73.2	127.3	106.2							59.1	38.0
	7	38.4	13.7	54.9	30.3	87.9	63.4	121.0	96.4	147.7	119.6					68.9	44.3
	8			48.5	20.4	81.6	53.5	114.7	86.5	141.5	109.8	180.8	152.7	201.2	165.7	78.7	50.6
	9					75.3	43.7	108.4	76.8	135.1	99.6	174.5	142.9	194.8	156.2	88.6	56.9
	10					68.9	33.4	102.0	66.5	128.7	90.1	168.2	132.6	188.6	146.7	98.4	63.3
	11							95.7	57.0	122.5	80.6	161.8	123.1			108.3	69.6
12							89.4	47.5			155.5	113.6			118.1	75.9	
AT125SR	5	73	47	98	72	148	122									79	52
	6	63	31	88	56	138	107	188	157							94	63
	7	52	15	87	40	127	90	178	141	217	176					110	73
	8			67	25	117	75	167	125	207	159	268	226	297	245	125	84
	9					107	59	157	109	196	144	257	210	286	228	141	94
	10					96	44	146	94	186	128	247	194	276	213	157	105
	11							136	78	176	113	236	178			173	115
12							125	63			226	163			188	125	
AT140SR	5	128	85	171	127	256	213									129	86
	6	111	59	154	102	239	187	325	273							155	103
	7	94	33	137	76	222	162	308	247	376	307					181	120
	8			120	50	205		291	221	358	281	462	392	512	426	206	137
	9					187	110	273	196	341	255	444	367	495	400	232	155
	10					170	84	256	169	324	229	427	340	478	374	258	172
	11							238	143	307	203	409	314			284	189
12							221	118			392	289			310	206	
AT160SR	5	193	124	259	191	392	324									208	140
	6	165	83	232	149	365	282	498	415							250	168
	7	137	41	203	107	336	240	469	373	575	465					292	196
	8			176	66	309	199	442	237	546	423	708	598	785	647	333	223
	9					280	157	413	290	519	381	679	556	757	606	375	251
	10					253	115	386	248	491	340	652	514	729	564	417	279
	11							358	207	463	298	624	473			458	307
12							330	165			596	431			500	335	
AT190SR	5	332	222	438	329	651	542									309	200
	6	292	161	398	267	611	480	824	693							371	240
	7	252	99	358	205	571	418	784	631	957	782					433	280
	8			318	143	531	356	744	569	917	720	1169	995	1302	1084	495	320
	9					491	295	704	507	877	658	1130	933	1263	1022	557	360
	10					451	233	664	446	837	597	1090	871	1223	960	618	400
	11							624	384	797	535	1050	809			680	440
12							584	322			1010	748			742	480	

Torque Output(Unit: NM) – Spring-Return Actuators

Torque output(Unit: NM) – Spring-return actuators																Spring torque output		
Model	Spring number	2.5Bar		3Bar		4Bar		5Bar		6Bar		7Bar		8Bar		90° Start	0° End	
		0° Start	90° End	0° Start	90° End	0° Start	90° End	0° Start	90° End	0° Start	90° End	0° Start	90° End	0° Start	90° End			
AT210SR	5	390	285	523	418	789	684									380	275	
	6	335	209	468	342	734	608	1000	874							456	330	
	7	280	133	413	266	679	532	945	798							532	385	
	8			358	190	624	456	890	722	1156	988	1422	1254			608	440	
	9					569	380	835	646	1101	912	1367	1178			684	495	
	10					514	304	780	570	1046	836	1312	1102	1578	1368	760	550	
	11							725	494	991	760	1257	1025	1523	1292	836	605	
	12							670	418	936	684	1202	950	1468	1216	912	660	
	AT240SR	5	552	409	744	600	1129	985									554	410
		6	470	297	662	489	1047	874	1432	1259							665	492
		7	388	187	580	379	964	764	1349	1149							775	575
		8			498	268	883	653	1267	1037	1652	1422	2037	1807			886	656
9						800	542	1185	926	1569	1311	1954	1696			998	739	
10						718	431	1103	816	1488	1201	1872	1586	2257	1970	1108	821	
11								1021	705	1406	1090	1791	1474	2176	1859	1219	903	
12								939	594	1323	979	1708	1363	2093	1748	1330	985	
AT270SR		5	903	675	1195	968	1779	1552									787	560
		6	790	519	1083	811	1667	1396	2252	1981							943	672
		7	679	361	972	654	1556	1238	2141	1823							1101	783
		8			860	497	1444	1081	2029	1666	2614	2252	3199	2836			1258	895
	9					1332	923	1917	1509	2502	2094	3087	2678			1416	1007	
	10					1220	767	1805	1352	2390	1937	2974	2521	3560	3107	1572	1119	
	11							1693	1194	2278	1779	2862	2364	3448	2949	1730	1231	
	12							1582	1037	2167	1623	2751	2207	3336	279	1887	1342	
	AT300SR	5	1097	729													1061	730
		6	935	494	1316	875											1273	876
		7	772	258	1153	639	1916	1402									1485	1022
		8			991	403	1754	1166	2517	1929							1697	1168
9						1592	930	2355	1693	3118	2456					1909	1314	
10						1430	695	2193	1458	2956	2221	3719	2984	4482	23747	2122	1460	
11								2030	1222	2793	1985	3556	2748	4319	3511	2334	1606	
12								1868	986	2631	1749	3394	2512	4157	3275	2546	1752	
AT350SR		5	1553	964													1702	1173
		6	1292	586	1863	1157											2043	1408
		7	1031	208	1602	779	2745	1922									2383	1642
		8			1341	401	2484	1544	3626	2686							2724	1877
	9					2224	1165	3336	2307	4508	3449					3064	2112	
	10					1963	787	3105	1929	4247	3071	5390	4214	6532	5356	3405	2346	
	11							2844	1551	3986	2693	5129	3836	6271	4978	3745	2581	
	12							2584	1172	3726	2314	4869	3457	6011	4599	4086	2816	
	AT400SR	7	2028	869													2880	1837
		8	1736	411	2550	1225											3292	2100
		9			2259	768	3887	2396									3703	2362
		10			1968	311	3595	1939	5223	3567							4115	2642
11						3303	1482	4931	3110	6559	4738					4526	2887	
12						3012	1025	4640	2653	6268	4281	7895	5908	9623	7536	4938	3149	
13								4348	2195	5976	3823	7603	5450	9231	7078	5349	3412	
14								4057	1738	5685	3366	7312	4993	8940	6621	5761	3674	
15								3765	1281	5393	2909	7020	4536	8648	6164	6172	3937	
16										5101	2452	6728	4079	8356	5707	6584	4199	

Overall Dimensions & Valve Mounting Dimensions

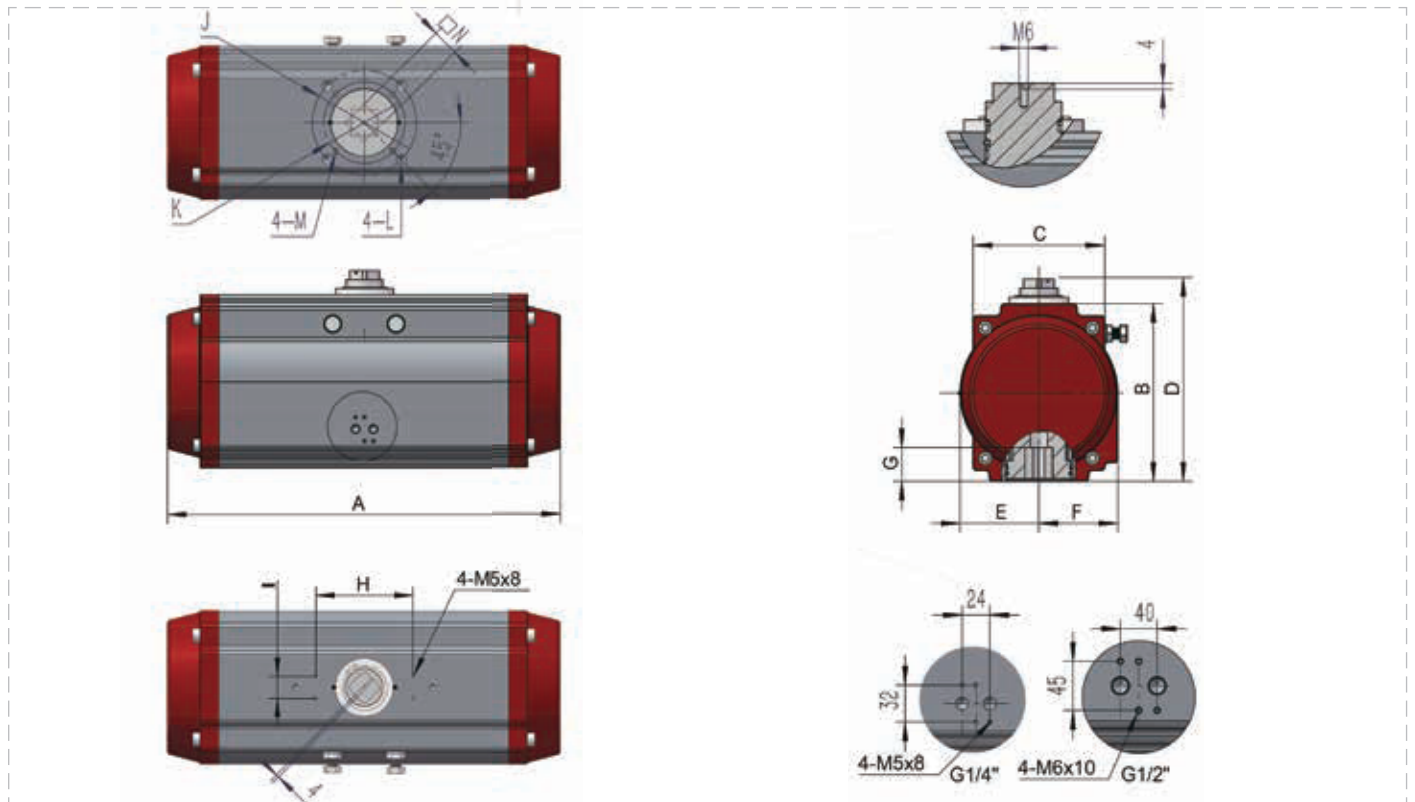

Dimensions

Unit: mm

Model	A	B	C	D	E	F	G	H	I	N	J	K	L	M	Air connection
AT-032	110	45	45	65	22.5	22.5	11	50	25	9	F03	—	M5x 7.5	—	1/8"
AT-052	147	72.8	60.5	92	26	41.5	14	80	30	11	F05	F03	M6x 10	M5x 7.5	1/4"
AT-063	170	90.5	70	110	33.5	47	17	80	30	14	F07	F05	M8x 13	M6x 10	1/4"
AT-075	186	100	78	120	39	53	17	80	30	14	F07	F05	M8x 13	M6x 10	1/4"
AT-083	206	109	86	129	40	57	20	80	30	14	F07	F05	M8x 13	M6x 10	1/4"
AT-092	262	117.6	92	137	44.5	58.5	20	80	30	17	F07	F05	M8x 13	M6x 10	1/4"
AT-105	268	135	104.8	155	52	64	26	80	30	17	F10	F07	M10x 16	M8x13	1/4"
AT-125	298	157	120	185	60	74.5	26	130	30	22	F10	F07	M10x 16	M8x 13	1/4"
AT-140	398	174	125	204	65	77	30	130	30	27	F12	F10	M12 x 20	M10x 16	1/4"
AT-160	456	198.5	143	229	74	87	30	130	30	27	F12	F10	M12x 20	M10x 16	1/4"
AT-190	534	232	172.8	262	86	103	40	130	30	36	F14	—	M16x 20	—	1/4"
AT-210	536	265	194	295	97	113	43	130	30	36	F14	—	M16x 20	—	1/1"
AT-240	620	290	223	320	115	130	50	130	30	46	F16	—	M20x 25	—	1/4"
AT-270	722	326	252	356	126	147	50	130	30	46	F16	—	M20x 25	—	1/2"
AT-300	784	354	335	384	162	173	50	130	30	46	F16	—	M20x 25	—	1/2"
AT-350	845	410	385	440	190	195	50	130	30	46	F16	—	M20x 25	—	1/2"
AT-400	956	466	520	496	260	260	60	130	30	55	F25	—	8-M16x 20	—	1/2"

*ISO 5211标准尺寸

Mounting Ports



Air supply interfaces compliant with NAMUR standard enable easy and efficient installation for solenoid

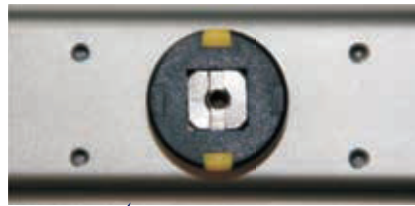

Pinion shaft to NAMUR standard, along with the mounting holes as standard on the top of actuator body enable direct installation for limited switch and valve positioner.



The bottom mounting holes to ISO5211 and DIN3337 standards allow actuators to connect directly onto manual gear operators or valve brackets.

Weight

Air Consumption Volume Operating Time

Model	Double action (unit:KGS)		Model	Open direction (unit:L)		Model	Double action		Single action	
	Opening	Closing		Opening	Closing		Opening	Closing	Opening	Closing
AT052	1.4	1.5	AT052	0.12	0.16	AT052	0.2	0.3	0.25	0.35
AT063	2.0	2.1	AT063	0.21	0.23	AT063	0.3	0.3	0.35	0.35
AT075	2.7	2.9	AT075	0.30	0.34	AT075	0.3	0.4	0.35	0.5
AT083	3.1	3.6	AT083	0.43	0.47	AT083	0.4	0.5	0.5	0.6
AT092	4.6	5.2	AT092	0.64	0.73	AT092	0.5	0.6	0.6	0.7
AT105	6.8	6.9	AT105	0.95	0.88	AT105	0.7	0.8	0.75	0.9
AT125	9.0	10.1	AT125	1.60	1.40	AT125	0.9	1.1	1.1	1.4
AT140	13.2	15.6	AT140	2.50	2.20	AT140	1.2	1.4	1.4	1.8
AT160	20.1	24	AT160	3.7	3.2	AT160	1.5	1.7	1.7	2.1
AT190	31.3	35.3	AT190	5.9	5.4	AT190	2.0	2.2	2.2	2.8
AT210	46.8	54.8	AT210	7.5	7.5	AT210	2.7	3.2	3.2	4.0
AT240	67.3	80.2	AT240	11.0	9.0	AT240	3.5	4.0	4.0	4.6
AT270	96.9	118	AT270	17.0	14.0	AT270	4.0	4.5	4.5	5.0
AT300	110	130	AT300	23.8	29.7	AT300	5.0	5.5	6.5	7.5
AT350	186	234	AT350	35.1	46.3	AT350	6.0	7.0	7.5	8.5
AT400	289	360	AT400	52.6	56	AT400	13.0	15.0	15.0	18.0

The operating time of actuators is tested in the following conditions: 1) Room temperature; 2) Stroke:0° to 90°; 3) Solenoid valve with its interface's diameter of 4mm, and the flow rate of Qn400 L/min; 4) Size of the gas tube: 8 mm; 5) Neutral clean air supply; 6) Air supply pressure: 5.5bar; 7) Unloaded operation Note: More accurate performance of operating time depends on actual parameters.

Mounting Dimentions - Output Holes (Customized Solutions)

Unit : mm

Model	AT52	AT63	AT75	AT83	AT92	AT105	AT125	AT140	AT160	AT190	AT210	AT240	AT270	AT300
	DA/SR	DA/SR	DA/SR	DA/SR	DA/SR	DA/SR	DA/SR	DA/SR	DA/SR	DA/SR	DA/SR	DA/SR	DA/SR	DA/SR
ΦR	13	13	13	16	19	22	22	28	28	32	32	34	38	42
S	14.2	14.2	14.2	18.4	21.6	24.8	24.8	32.1	32.1	35.3	35.3	37.4	42.4	45.3
T	3	3	5	5	5	5	5	8	8	8	8	10	10	12
U	32	32	32	32	32	45	45	45	45	45	45	51	51	65
ΦDR	13	13	13	16.1	19.2	22.4	22.4	28.8	28.8	32	32	33.6	38.4	41.5
HT	10	10	10	12	14	17	17	22	22	24	24	27	27	32

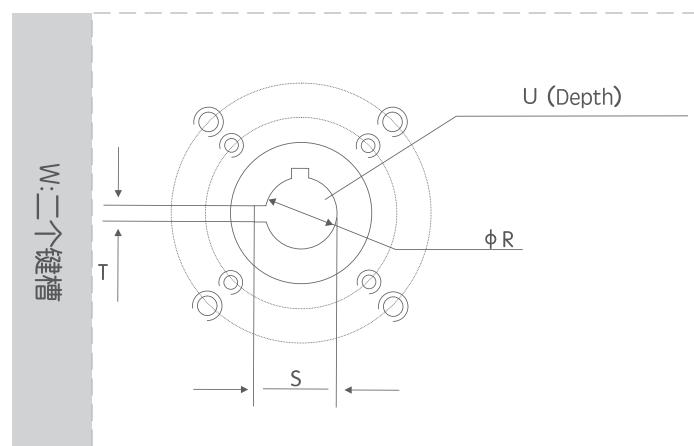
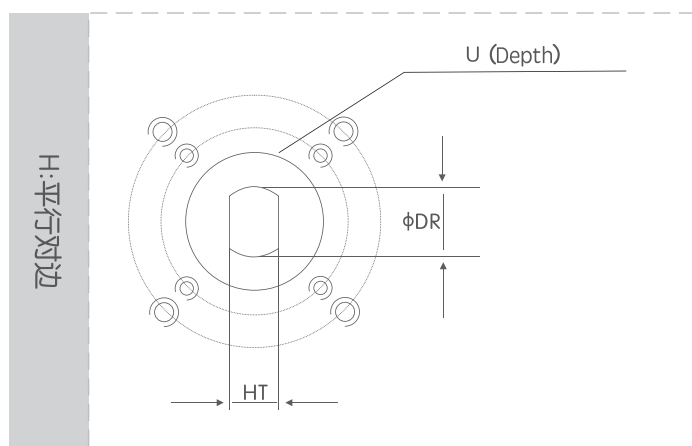

Special Rotation Actuators

With adjustable stroke bolts at both ends, special rotation actuators offer an extended range of rotation, from 0° to 90°, to custom-tailored lengths between 120° and 180°, or extended travel stops.

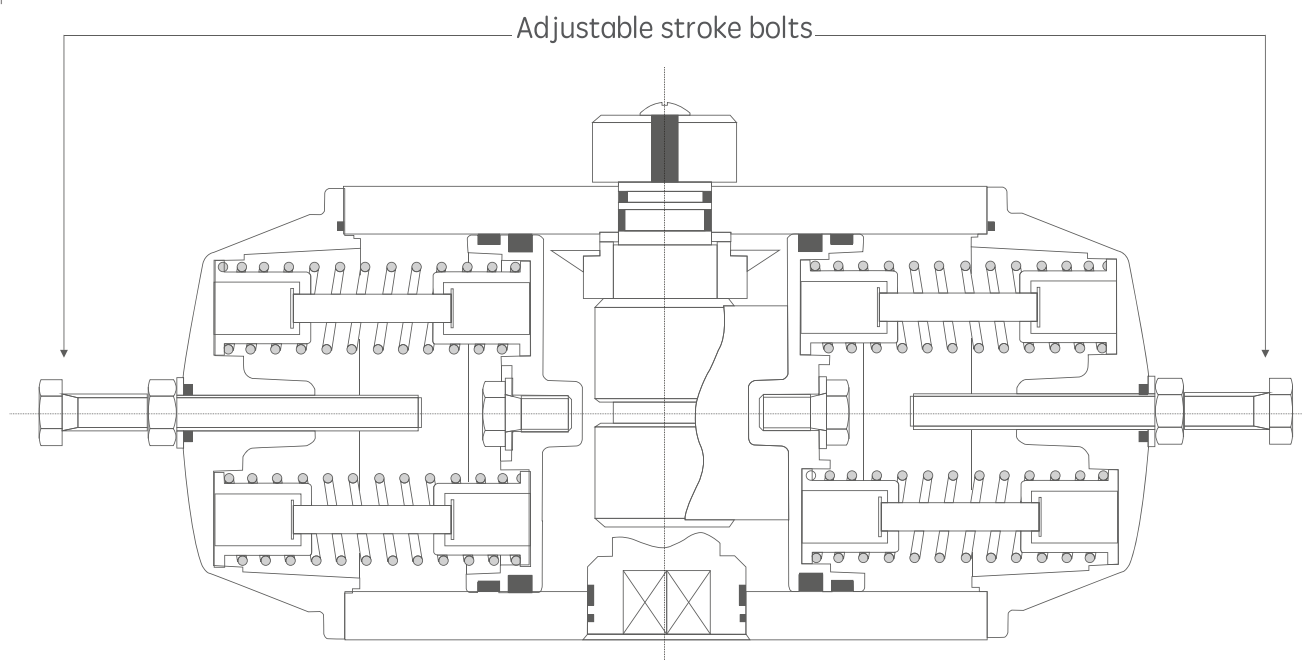

Overall Dimensions – Special Rotation Actuators (Double-Acting)

— 120°/180° rotation actuators —

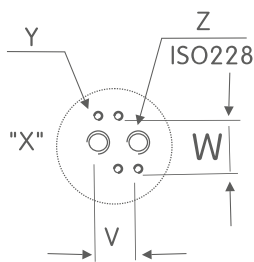
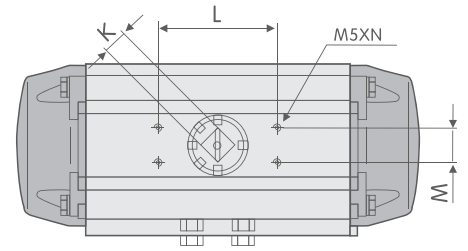
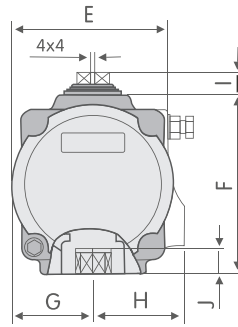
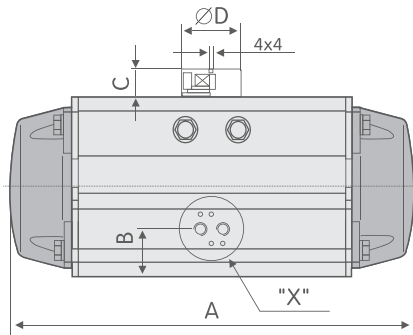

Conforms to NAMUR standard

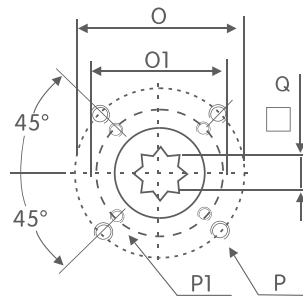

Conforms to mounting standard
ISO5211/VDI/VDE3845

Special solutions can be customized, for instance 140°/160° rotation or other models that are not covered by our standard range, dependent on the application or customer requirements.

Mounting Dimensions – Special Rotation Actuators (Double-Acting)

Model	AT52 DR	AT63 DR	AT75 DR	AT83 DR	AT92 DR	AT105 DR	AT125 DR	AT140 DR	AT160 DR	AT190 DR	AT210 DR	AT240 DR	AT270 DR	AT300 DR
ISOflange	-	F05	F05-7	-	F07-10	-	F07-10	-	F10-12	-	F14	-	-	-
A(120°)	-	183	243	-	309	-	397	-	504	-	622	-	-	-
A(180°)	-	225	305	-	385	-	495	-	630	-	775	-	-	-
B	-	30	30.5	-	37.5	-	45	-	52	-	62.5	-	-	-
C	-	20	20	-	20	-	30	-	30	-	50	-	-	-
ΦD	-	40	40	-	40	-	56	-	65	-	80	-	-	-
E	-	72	84.5	-	111	-	136	-	169	-	213	-	-	-
F	-	85	102	-	127	-	157	-	196	-	245	-	-	-
G	-	36	42.5	-	56	-	69.5	-	88	-	110	-	-	-
H	-	47	52	-	67	-	82	-	99	-	112	-	-	-
I	-	14.5	14.5	-	14.5	-	24.5	-	24.5	-	44.5	-	-	-
Jmin	-	16	16	-	19	-	24	-	29	-	38	-	-	-
K	-	11	17	-	17	-	27	-	27	-	36	-	-	-
L	-	80	80	-	80	-	80	-	80	-	130	-	-	-
M	-	30	30	-	30	-	30	-	30	-	30	-	-	-
N	-	8	8	-	8	-	8	-	8	-	8	-	-	-
ΦO1	-	50	50	-	70	-	70	-	102	-	140	-	-	-
ΦO	-	-	70	-	102	-	102	-	125	-	-	-	-	-
P1	-	4-M16	4-M6	-	4-M8	-	4-M8	-	4-M10	-	4-M16	-	-	-
P	-	-	4-M8	-	4-M10	-	4-M10	-	4-M12	-	-	-	-	-
□Q	-	14	14	-	17	-	22	-	27	-	36	-	-	-
ΦR	-	-	-	-	-	-	-	-	-	-	-	-	-	-
S	-	-	-	-	-	-	-	-	-	-	-	-	-	-
T	-	-	-	-	-	-	-	-	-	-	-	-	-	-
U	-	-	-	-	-	-	-	-	-	-	-	-	-	-
V	-	24	24	-	24	-	24	-	24	-	24	-	-	-
W	-	32	32	-	32	-	32	-	32	-	32	-	-	-
Y	-	M5*8	M5*8	-	M5*8	-	M5*8	-	M5*8	-	M5*8	-	-	-
Z	-	1/8"	1/8"	-	1/4"	-	1/4"	-	1/4"	-	1/4"	-	-	-

Three-Stage Pneumatic Actuators

Three-stage pneumatic actuators are available in two models, 0° - 45° - 90° and 0° - 90° - 180° , and the piston moves toward both ends after the air intake "2" is designed to assist the piston at both ends to create mechanical restrictions to achieve the middle position, which can be easily adjusted by directly using the external ends of the adjustment bolts, such as 20° , 30° , 50° , 75° and 95° , 120° , 130° , 150° , 175° etc.



Working Principle

The operation of the three-position pneumatic actuator requires the design of a solenoid control loop system to complete the operation, the control principle is as follows:

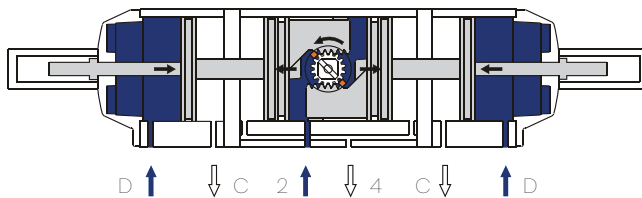

Position 1 (In the middle)

The air source pressure enters both the 2 and 4 mouths, the air is discharged from the 4 and C mouths, the 2 mouths move as internal pistons, and the D-port is positioned in the predetermined middle position by the auxiliary piston pushrods to limit the internal pistons.

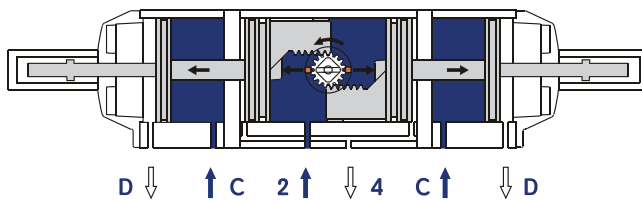

Position 2 (Full open position)

The air source pressure enters both 2 and C mouths, air is discharged from 4 mouths and D mouths, the internal piston of 2 mouths continues to move, and the C port is positioned to lift the auxiliary piston pushrod, so that the internal piston can reach the full open position smoothly.

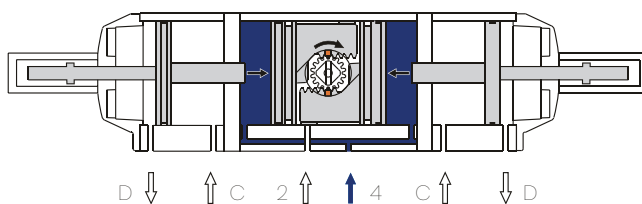

Position 3 (Fully closed position)

The air source pressure enters 4 mouths, the air is discharged from 2 mouths, and the internal piston moves in the direction between the mid-ranges to reach the full clearance position. Available in the 0° - 45° - 90° -degree spring-back-position model specification, the internal piston is forced to return to the full-off position by means of a spring during a gas-off (or gas source failure).

Three-Stage Pneumatic Actuators

— 0°-45°90° rotation actuators —

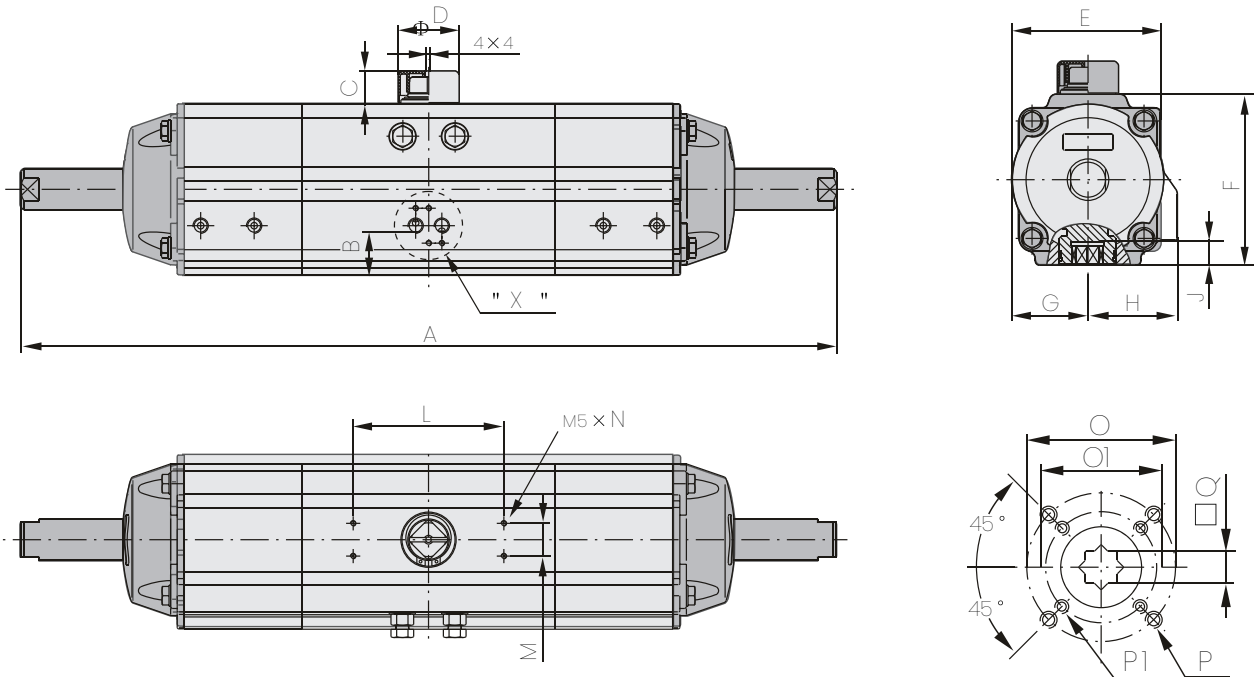

Special solutions can be customized, for instance 140°/160° rotation or other models that are not covered by our standard range, dependent on the application or customer requirements.

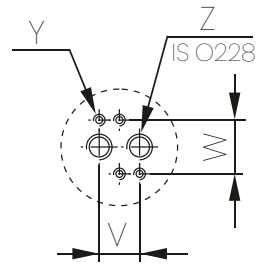

Conforms to mounting standard ISO5211/VDI/VDE3845

" X " Conforms to NAMUR standard

Mounting Dimensions - Three-stage Pneumatic Actuators

Model	A		B	C	φD	E	F	G	H	J	L	M	N	O1	O	P1	P	□Q	V	W	Y	Z
	0°-45°-90°	0°-90°-180°																				
AT63	390	440	30	20	40	72	85	36	47	16	80	30	8	50	—	4-M6	—	14	24	32	M5X 8	1/8"
AT75	480	570	30.5	20	40	84.5	102	42.5	52	16	80	30	8	50	70	4-M6	4-M8	14	24	32	M5X 8	1/8"
AT105	600	710	37.5	20	40	111	127	56	67	19	80	30	8	70	102	4-M8	4-M10	17	24	32	M5X 8	1/4"
AT125	720	910	45	30	56	136	157	69.5	82	24	80	30	8	70	102	4-M8	4-M10	22	24	32	M5X 8	1/4"
AT160	915	1130	52	30	65	169	196	88	99	29	80	30	8	102	125	4-M10	4-M12	27	24	32	M5X 8	1/4"
AT210	1155	1400	62.5	30	80	213	245	110	112	38	130	30	8	140	—	4-M16	—	36	24	32	M5X 8	1/4"

Torque Output(Nm) - Double-Acting Actuators

Model	3.0bar	4.0bar	5.0bar	6.0bar	7.0bar	8.0bar
AT63	21.7	28.9	36.1	43.4	50.6	57.8
AT75	30	40	50	60	70	80.1
AT105	98	130	163	196	228	261
AT125	153	204	255	306	357	408
AT160	397	530	662	794	927	1059
AT210	880	1173	1466	1760	2053	2346

Torque Output(Nm) - Spring-Return Actuators

Model	Spring number	Spring torque output(Unit:bar)														Spring output torque	
		2.5Bar		3Bar		4Bar		5Bar		6.0Bar		7Bar		8Bar		90°	0°
		0° Start	90° End	0° Start	90° End	0° Start	90° End	0° Start	90° End	0° Start	90° End	0° Start	90° End	0° Start	90° End	Start	End
AT63	5	11.4	7.7	15.0	11.4	22.3	14.9									10.4	6.8
	6	10.1	5.7	13.6	9.3	20.9	16.6	28.3	23.9							12.5	8.2
	7	8.6	3.6	12.5	7.2	19.5	14.5	26.8	21.9							14.6	9.6
	8			10.9	5.1	18.2	12.4	25.5	19.8	32.8	27.0	40.1	34.3			16.7	0.9
	9					16.8	10.4	24.1	17.7	31.4	24.9	38.7	32.2			18.8	12.3
	10					1.4	8.2	22.8	15.6	30.0	22.8	37.3	30.1	44.7	37.4	20.9	13.7
	11							21.5	13.5	28.7	20.7	36.0	28.0	43.3	35.3	22.9	15.0
	12						20.0	11.4	27.3	18.6	34.6	25.9	41.9	33.3	25.0	16.4	
AT75	5	14.5	10.6	19.4	15.5	29.5	25.7									14.5	10.5
	6	12.4	7.6	17.3	12.6	27.4	22.7	37.5	32.8							17.4	12.7
	7	10.4	4.8	15.2	9.7	25.3	19.9	35.4	29.9							20.3	14.8
	8			13.1	6.8	23.1	16.9	33.3	27.0	43.2	37.0	53.3	47.0			23.2	16.9
	9					21.0	14.1	34.2	24.1	41.1	34.1	51.2	44.2			26.1	19.0
	10					19.0	11.1	28.8	21.2	39.0	31.2	49.1	41.2	59.1	51.2	29.0	21.1
	11							27.0	18.3	37.0	28.3	47.0	38.4	57.0	48.4	31.9	23.2
	12						24.9	15.4	34.9	25.4	44.9	35.4	54.9	45.4	34.7	25.3	
AT105	5	51.0	33.4	67.5	49.9	100.6	83.0									49.2	31.6
	6	44.7	23.5	61.1	40.0	94.2	73.2	127.3	106.2							59.1	38.0
	7	38.4	13.7	54.9	30.3	87.9	63.4	121.0	96.4	147.7	119.6					68.9	44.3
	8			48.5	20.4	81.6	53.5	114.7	86.5	141.5	109.8	180.8	152.7	201.2	165.7	78.7	50.6
	9					75.3	43.7	108.4	76.8	135.1	99.6	174.5	142.9	194.8	156.2	88.6	56.9
	10					68.9	33.4	102.0	66.5	128.7	90.1	168.2	132.6	188.6	146.7	98.4	63.3
	11							95.7	57.0	122.5	80.6	161.8	123.1			108.3	69.6
	12						89.4	47.5			155.5	113.6			118.1	75.9	
AT125	5	73	47	98	72	148	122									79	52
	6	63	31	88	56	138	107	188	157							94	63
	7	52	15	87	40	127	90	178	141	217	176					110	73
	8			67	25	117	75	167	125	207	159	268	226	297	245	125	84
	9					107	59	157	109	196	144	257	210	286	228	141	94
	10					96	44	146	94	186	128	247	194	276	213	157	105
	11							136	78	176	113	236	178			173	115
	12						125	63			226	163			188	125	
AT160	5	193	124	259	191	392	324									208	140
	6	165	83	232	149	365	282	498	415							250	168
	7	137	41	203	107	336	240	469	373	575	465					292	196
	8			176	66	309	199	442	237	546	423	1169	598	785	647	333	223
	9					280	157	413	290	519	381	1130	556	757	606	375	251
	10					253	115	386	248	491	340	1090	514	729	564	417	279
	11							358	207	463	298	1050	473			458	307
	12						330	165			1010	431			500	335	
AT210	5	390	285	523	418	789	684									380	275
	6	335	209	468	342	734	608	1000	874							456	330
	7	280	133	413	266	679	532	945	798							532	385
	8			358	190	624	456	890	722	1156	988	1422	1254			608	440
	9					569	380	835	646	1101	912	1367	1178			684	495
	10					514	304	780	570	1046	836	1312	1102	1578	1368	760	550
	11							725	494	991	760	1257	1025	1523	1292	836	605
	12						670	418	936	684	1202	950	1468	1216	912	660	

Stainless Steel Pneumatic Actuator



- (1) The design of rack-and-pinion double-piston symmetrical structure enables fast and steady action, high precision, high output power as well as reverse rotation by simply changing the installation position of the piston.
- (2) The extruded high-quality aluminum alloy cylinder, the processed inner bore by precision machining center, and hard anodized external surface of (anodic oxidation + Teflon coating under special circumstances) enable its longer service life and low friction coefficient.
- (3) The integrated design enables all models of double-action actuators and single-action actuators have the same cylinder and end cap, which makes it convenient for changing action mode by assembling springs or disassembling springs.
- (4) The combined preload safe spring assembly is safe and convenient for assembling or removing springs both in the installation process and on the operation site.
- (5) The two separate adjusting screws on the external side, which are intended for the actuator installed on the valve, enable accurate and convenient adjustment of the OPEN or CLOSE position of the valve.
- (6) The multifunctional position indicator is capable of on-site visual indication; besides, its slot, consistent with VID/V-IE3845 and NAMUR standards, enables installation and output all accessories, such as the limit switch box, electric positioner and position sensor.
- (7) The gas source interface, in line with NAMUR standard, is capable of direct installation of the NAMUR standard solenoid valve.
- (8) The rack composite bushing and piston guide ring on the back of the rack as well as the bearing of the output shaft etc. Are intended for preventing metal-to-metal friction and increasing lubrication, to enable low friction and long service life.
- (9) All fasteners are made of stainless steel to enable long-term corrosion resistance.
- (10) The connection parts are in line with new international standards ISO5211 and DIN3337(F03-F25), to enable interchange and common use.

Model Number Designation

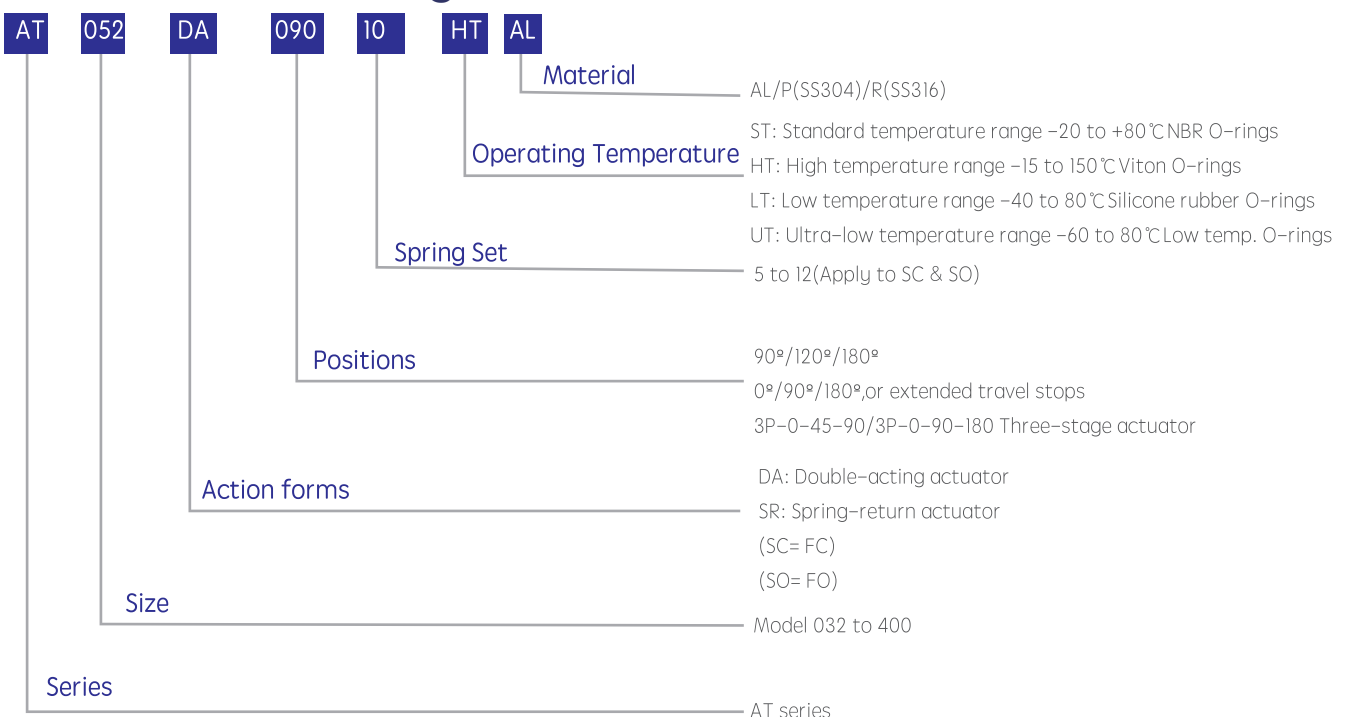

On-off Valve Accessories

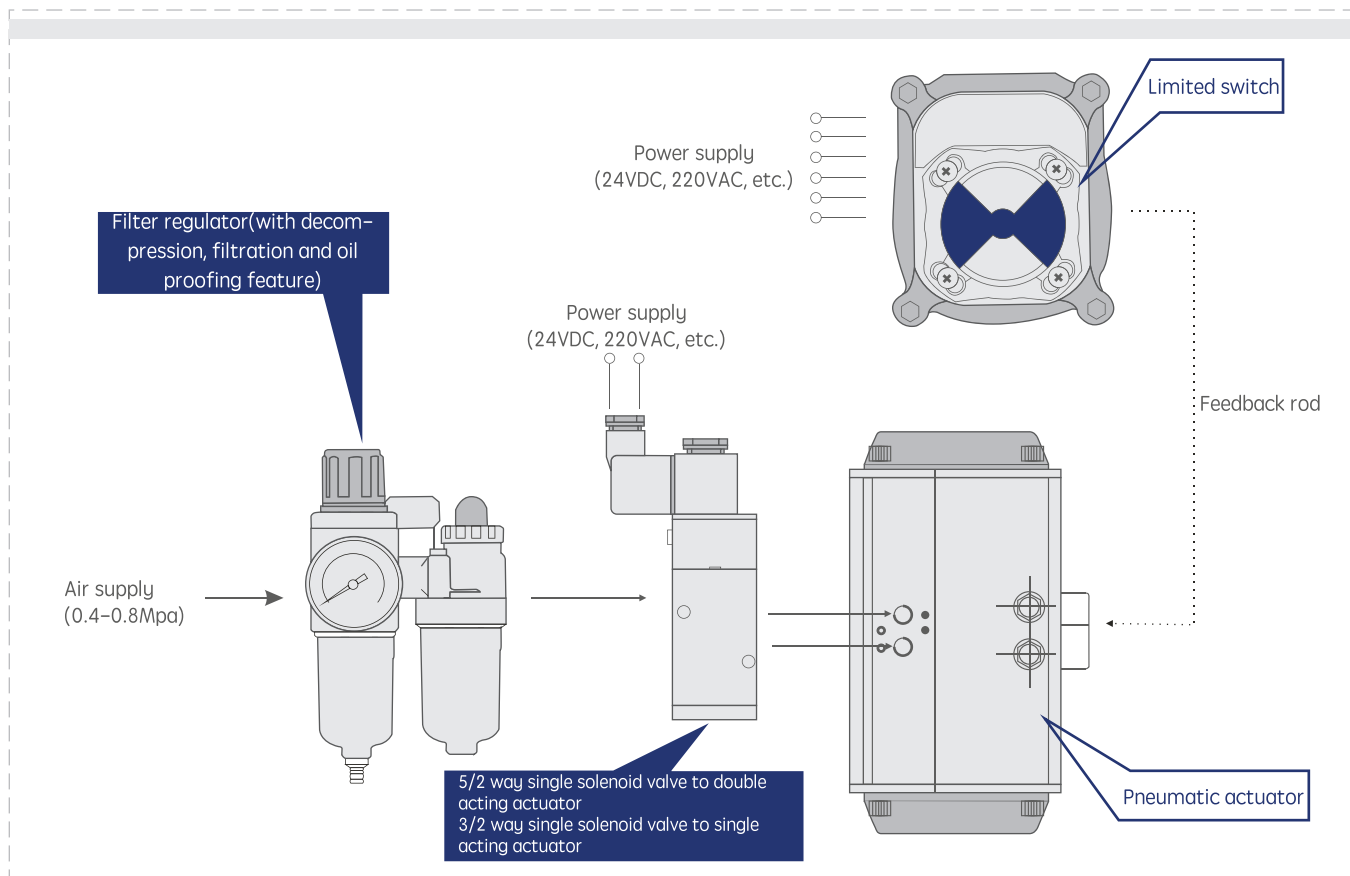

On-off Valve Accessories

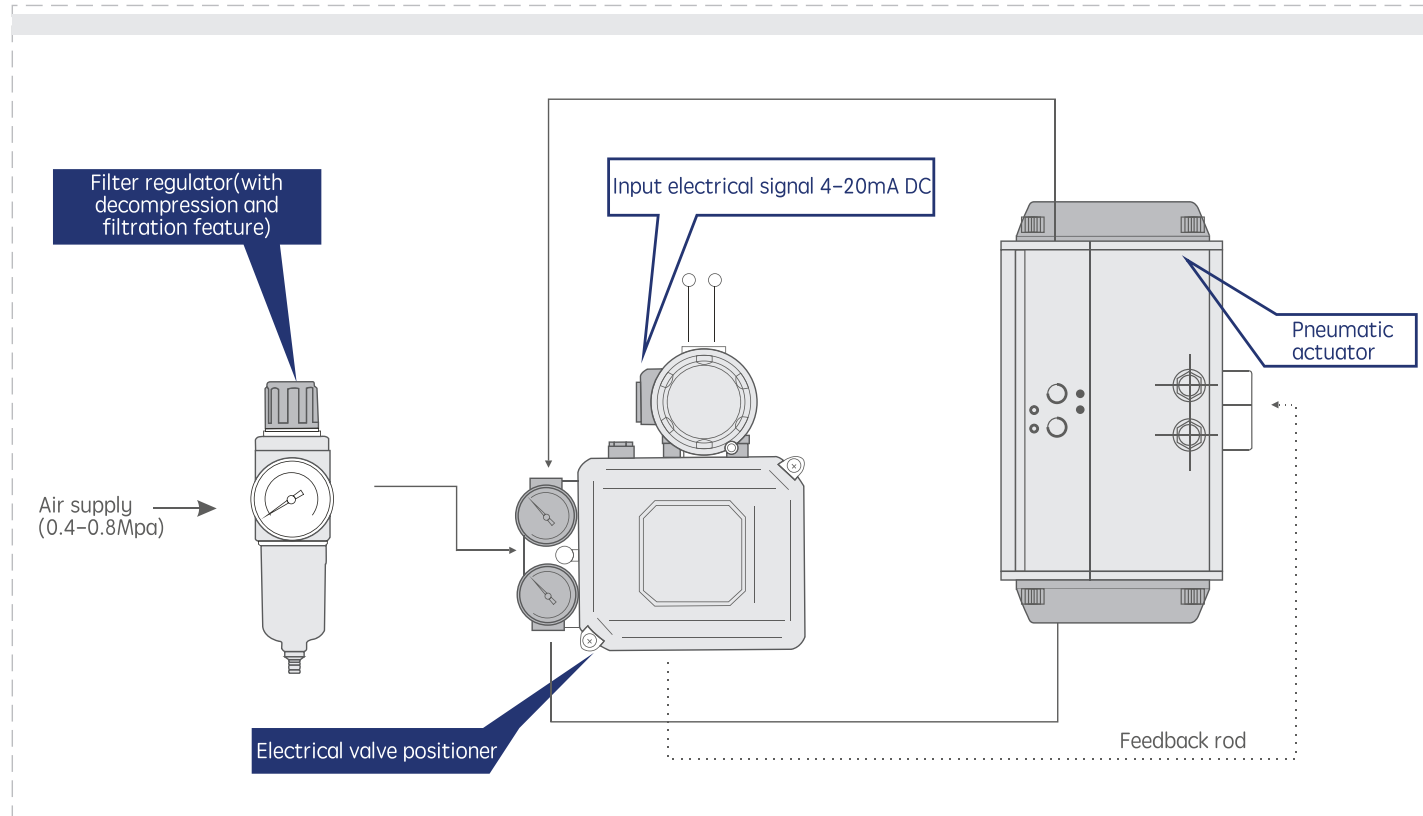

General Troubleshooting Procedure

Problems	Inspection	Solutions
Pneumatic valve isn't working	The solenoid valve or its coil is damaged./The solenoid ports are plugged.	Replace the solenoid valve or its coil./Remove contaminants attached on the solenoid ports.
	Test with the actuator under air supply pressure, to check the piston seals for leaking and the actuator for damage.	Replace the worn down piston seals or damaged actuator.
	The valve is plugged with contaminants.	Remove contaminants or replace the damaged parts.
	The valve is switched to manual mode.	Turn the handle of gear operator back to pneumatic mode.
Pneumatic valve is acting slowly, sluggishly	The motive pressure is incorrect.	Increase the air supply pressure to 0.4–0.7Mpa.
	The actuator is undersized with insufficient torque output.	Select the correct actuator model.
	There are problems with the valve binding or the other parts.	Re-adjust the valve binding.
	The power gas pressure is too low./The tubing connected to the gas is plugged.	Replace the accessories with larger ports./Remove blockage or filter
There is no indication from limited switch.	There is a power board failure.	Check and repair power supply.
	The position of limited switch cam is not in a accurate position.	Adjust the limited switch cam to correct position.
	Microswitch has failed.	Replace the microswitch.

Solenoid Valve

ASCO Solenoid Valve

Features

- Compact spools that can be converted from 3/2 to 5/2
- NAMUR standard
- Standard manual operation
- DIN, waterproof and explosion-proof solenoid valves are available.



Standard Type



Standard Type(EX)



Exd(Aluminum alloy)



Exd(SS body)

- Exhaust gas from spring position to protect actuators from corrosion
- Operating temperature range -4 to +140 °F (-20 to +60 °C)
- All of threaded bolts connecting to ports can be provided in stainless steel, allow for highly corrosive atmospheres.

Explosion-Proof Solenoid Valve

BK-4M300 Series



Specification of Explosion-Proof Type

Explosion-proof rating	EExmIIT4
Voltage Range	+10%
Power Consumption	AC=4.4VA,DC=5W
Insulation Class	Class F

Specification

Model	BK- 4M310-08 BK 4M320-08
Me dium	Dry clean gas
Oper ating	Intemal Piloted
Valve Type	5/2-way, 3/2-way
Ort ce Size	35mm
Port Size	Inlet & Exhaust Port:PE1/4"
L ubrication	Not Required
Pressure Range	0.15 ~ 0.8Mpa
Proof Pressure	12bar
Temp. Range	-5 ~60 °C (23- 140° F)
Voltage Range	- 15%~10%
Power Consumption	AC=2.0~3.5VA, DC=2.5W
Insulation Class	Class F
Protecion	IP65(DIN40050)
Connector	Socket with Plug
Max Frequency	5 cycle/second

Note: Connecting port PT, PT are available. Ether 5/2 or 3/2-way can be exchanged by simply turning the O-ring Seals.

Limited Switch APL-2/3/4/5N Series



IP67, IP68

MODEL: APL-2N

- IP rating: IP67/NEMA4&4X as standard(IP68 optional)
- Solid and compact design
- Visual indication by position indicator
- Dual cable entry: 2 x 1/2 NPT as standard, M20, PG13.5, PFI/2", PT1/2" options
- Port: 8 points(0.08-2.5mm²)
- Captive cover bolts
- Stainless steel bracket & shaft to NAMUR standard



MODEL: APL-3N

- IP rating: IP67/NEMA4&4X as standard(IP68 optional)
- Solid and compact design
- 3~4 additional switches
- 8 ~ 16 additional port
- Visual indication by position indicator
- Dual cable entry: 2x 1/2 NPT as standard, M20, PG13.5, PFI/2" PT1/2" options
- Port: 8 points(0.08-2.5mm²)
- Captive cover bolts
- Stainless steel bracket & shaft to NAMUR standard



E EX d IIB T 6

MODEL: APL-4N

- IP rating: IP67/NEMA4&4X,7,9 as standard(IP68 optional)
- Explosionproof : E EX dIIB T6(NEPSI certified)
- Solid and compact design
- 3~4 additional switches
- 8~20 additional port
- Various options of switches
- Cable entry : 2 x 3/4 NPT as standard, M20, M25, PF3/4", PT3/4" 4 options
- Port: 8 points(0.08-2.5mm²)
- Stainless steel bracket & shaft to NAMUR standard



E EX d IIB T 6

MODEL: APL-5N

- IP rating: IP67/NEMA4&4X,7,9 as standard(IP68 optional)
- Explosionproof: E EX d IIC T6, E EX ia IIC T6, E EX dIIB T6
- Solid and compact design
- Shaft holder built in the cover(Dual shaft)
- Easy to set position indicator
- Unique design to mounting the cover by threaded bolts for fixing indicator
- Bolts on visual position indicator
- Dual Cable entry: 2x 3/4 PF as standard, M20, M25, NPT3/4", PT3/4" options
- Port: 8 points(0.08-2.5mm²)
- Captive cover bolts & Spring loaded cover bolts
- Unique design to hold connecting bolts tightly inside housings
- Easy installation to holders
- Stainless steel bracket & shaft to NAMUR standard

Air Filter Regulator

Body material: stainless steel 316

Environment & operating temperature range -40 to 80°C

Compliant with NACE standards

The JIS components of valve body and the component materials with certificates are meeting ANSI/NACE standards.

Specifications

Media	Dry clean gas
Operating temp. range	-40 to +80°C
Proof pressure	3.0 MPa
Maximum operating pressure	2.0 Mpa
Standard pressure range	0.05 to 0.85 MPa
Standard filtration rating	5µm
Drain capacity	AW30:20, AW40:80
Construction	Relieving type
Weight (KGS)	AW30:1.19, AW40:3.40

Applicable Model

Model	Port size
AW30	1/4, 3/8
AW40	1/4, 3/8, 1/2, 3/4



Standard Specifications

Model	AW20-A	AW30-A	AW40-A	AW40-06-A
Port size	1/8, 1/4	1/4, 3/8	1/4, 3/8, 1/2	3/4
Pressure gauge port size			1/8	
Ruid			Air	
Ambient and fluid temperature			-5 to +60°C	
Proof pressure			1.5MPa	
Maximum operating pressure			1.0MPa	
Set pressure range			0.05-0.7MPa	
Nominal filtration rating			5µm	
Drain capacity(cm³)	8	25	45	45
Bowl material			Polycarbonate	
Bowl guard	Stainless steel		Polycarbonate	
Construction			Relieving type	
Weight(kg)	0.21	0.41	0.75	0.81



Standard Specifications

Model	AC20-A	AC25-A	AC30-A	AC40-A	AC40-06-A	
Component	Air filter	AF20-A	AF30-A	AF30-A	AF40-A	AF40-06-A
	Regulstor	AR20-A	AR25-A	AR30-A	AR40-A	AR40-06-A
	Lubricator	AL20-A	AL30-A	AL30-A	AL40-A	AL40-06-A
Port size	1/8, 1/4	1/4, 3/8	1/4, 3/8	1/4, 3/8, 1/2	3/4	
Pressure gauge port size				1/8		
Ruid				Air		
Ambient and fluid temperature				-5~ 60°C (with no freezing)		
Proof pressure				1.5MPa		
Max. Operating pressure				1.0MPa		
Set pressure range				0.05-0.7MPa		
Nominal filtration rating				5µm		
Recommended lubricant				Class 1 turbine oil(ISO Vg32)		
Bowl material				Polycarbonate		
Bowl guard	Stainless steel			Polycarbonate		
Regulator construction				Relieving type		
Weight(kg)	0.39	0.67	0.82	1.26	1.43	



Gear Operators

Description

KH series worm gear operator offers simple and reliable manual application to quarter-turn valves, and is available for easy and direct mounting to actuators. All facilities are suitable for the use of both indoor and outdoor application. The modular design is to provide the most efficient and effective solution to a full range of manual overriding requirements.

Operation

To engage manual operation, first pull out the lock handle and then rotate the clutch lever in anti-clockwise direction until engagement takes place. To return to automatic mode, first pull out the lock handle and then rotate the clutch lever in clockwise direction until engagement takes place.

Specification

1. Body: Aluminum alloy
2. Gear guard: Ductile iron
3. Input shaft: ASTM A29M & Chrome-plated
4. Standard temperature range: -20 to 120°C (-40 to 248°F)
5. Stroke adjustment: ±5° at either end
6. Rotation range: 0 to 90°
7. Finish coat: Two polyurethane coat
8. IP rating: IP65
9. Torque range: 300 to 8500Nm



Technical Data

Model	Transmission ratio	Input torque (NM)	Torque output (NM)	Gear operator model	Weight (KGS)
KH-1	26:1	50	100	180	2.6
KH-2	30:1	60	215	200	4.0
KH-3	38:1	90	434	280	6.5
KH-4	54:1	110	1000	300	13
KH-5	80:1	140	2000	400	32
KH-6	78:1	200	3500	500	43
KH-7	98:1	200	4200	600	65
KH-8	100:1	200	6000	600	95

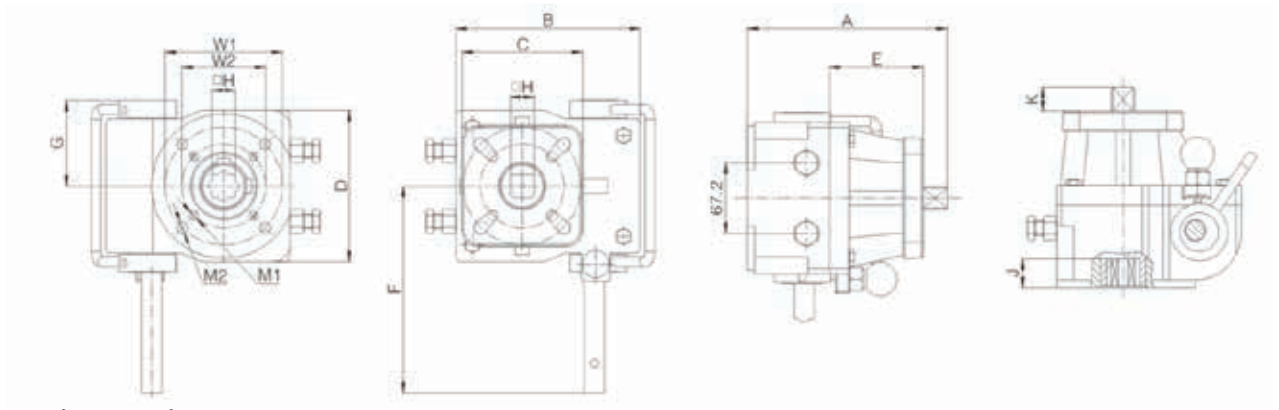

Overall Dimensions

Model	A	B	C	D	E	F	G	□H	J	K	M1	M2	W1	W2
KH-1	120	110	70	90	56	123	51	14	17	15	4-M6	4-M8	70	50
KH-2	127	132	102	122	55	157	63	17	19	18	4-M8	4-M10	102	70
KH-3	150	160	115	140	69	164	70	22	23	22	4-M12	4-M14	125	102
KH-4	194.5	201.8	130	230	83.5	240	92	27	29	28	4-M14	4-M16	140	125
KH-5	208.5	256	156	230	89.5	265	115	36	38	36	4-M16	4-M20	165	156
KH-6	233	298	160	240	94	330	120	46	50	48	4-M16	4-M20	165	160
KH-7	188	366	235	320	94	330	160	55	60	55	—	8-M16	235	200
KH-8	195	410	—	320	—	350	160	55	65	55	—	8-M16	—	254

Note: All dimensions are in mm.

HOW TO AVOID PROBLEMS

- Ball valves shall be transported and stored with the ball in the fully open position.
- Flanged ends and welded ends shall be protected.
- End protection shall be removed only when the valve is installed in the line.
- Valves shall be handled using the proper lifting lugs.
- Valves shall be stored according to Elite storage procedures. Long term storage shall be avoided.
- For welded-end valves, advise Elite if there will be a post weld heat treatment (transition pups may be necessary to avoid damages to seals).
- Flush and clean the line before operating the valve.
- Make sure no line-testing fluid is left in the line and/or the valve body.
- Avoid leaving the valve body filled with salt water to prevent internal corrosion.
- During line-testing, valves shall be left in the partially open position for the minimum possible amount of time.
- Standard ball valves shall be used for on-off service only. Throttling service (use of the valve with the ball partially open) can damage the seats.
- Make sure to take into consideration the actual service conditions when selecting materials for O-rings and seat inserts.
- Always specify anti-explosive decompression material for valves to be used in high pressure gas service.
- Make sure the selected actuator has been properly sized (an oversized actuator can be as dangerous as an undersized one).
- Advise Elite of cycle frequency to ensure proper sizing of actuator.
- Do not use the actuator to lift the valve.

◀ WARRANTY CLAUSE

Elite Flow Control products are delivered with a standard guarantee of good performance for the period of 18 months after the delivery date or 12 months of operation after commissioning.

Warning: The scope of Warranty is covered for manufacturing defects only. In case the valve failure is due to the wrong operations by the customer the warranty is not applicable.

In order to claim the warranty due to the manufacturing defects, the customer needs to prepare the detailed rejection report including the inspection procedure, operational report, pictures of valves, if this report proves that the fault is due to the manufacturing defect, Elite will provide the appropriate solution.



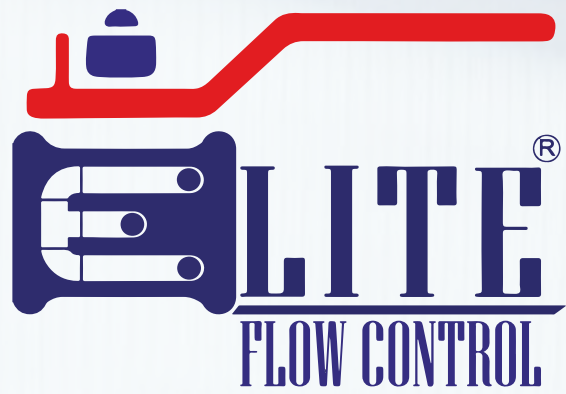

WE CONTROL THE FLOW

Elite Flow Control USA LLC

15730 W Hardy Rd Ste 340

Houston, TX 77060

Tel: 832-987-1774 / 832-539-6968

Email: contact@elitegocl.com

Web: www.eliteflowusa.com

www.elitegocl.com

